

Operating Instruction english

revision	A
date	18.09.2012
author	NH

This operating instruction is not subject to the updating

Fluidic multi-coupling

90405 (Z13/Z10)

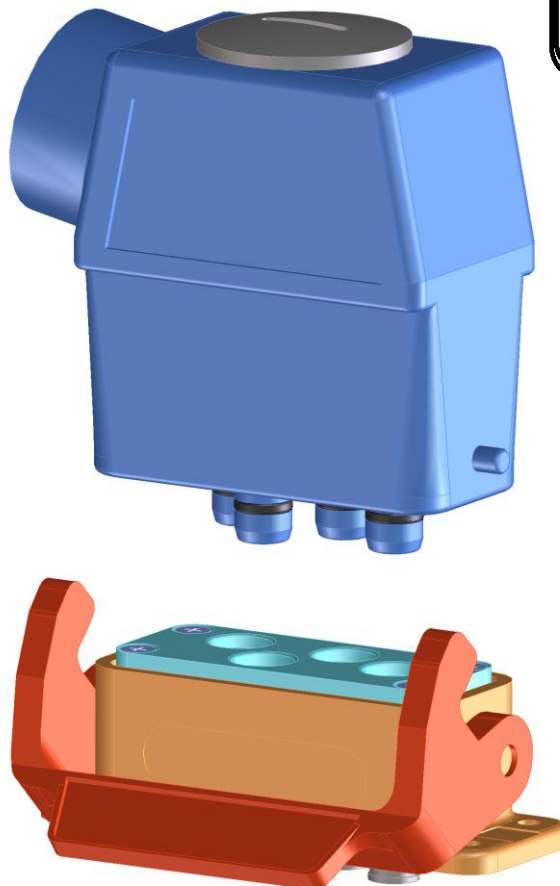

Vor Beginn aller Arbeiten
Betriebsanleitung lesen!

*Read operating instruction
before beginning of all works!*

Betriebsanleitung immer
AUFBEWAHREN!
griffbereit am Gerät

*Always KEEP operating
instruction! In a ready hand
way at the device*

Achtung: Vor Inbetriebnahme
Gerät auf mängelfreien Zustand
und technisch einwandfreie
Funktion kontrollieren.

*Caution: Before starting-up
check device on faultless
condition and technically
perfect function.*

Das Original ist die
deutsche Fassung

*The German version
is the original*

This fluidic multi-coupling is a quality product, in which special attention has been paid to high functionality, ease of operation, safety and reliability. As an item of technical equipment this fluidic multi-coupling is intended for use in the commercial, industrial area and for operators, who have been trained by specialists in the handling of technical systems / tools.

Customer care:

As part of our individual customer care we will be happy to assist you in questions relating to use and operation and on any problems encountered.

Service and maintenance:

In order to maintain the high technical performance capability and reliability of your fluidic multi-coupling over many years, we recommend regular inspection and maintenance.

We can thereby offer you optimum support by our Customer Service department and the conclusion of a service and maintenance contract. Please ask for a quotation.

Carl Kurt Walther GmbH & Co. KG
Westfalenstraße 2
42781 Haan

PO Box 42 04 44
42404 Haan
Germany

telephone: +49 (0) 2129/567-0
telefax: +49 (0) 2129/567-450

E-Mail: info@walther-praezision.de
Internet: www.walther-praezision.de

Contact:

Application technology and service

Holger R. Figge

telephone: +49 (0) 2129/567-591
telefax: +49 (0) 2129/567-590
mobile: +49 (0) 162/2090100
e-mail: hfigge@walther-praezision.de

Further addresses and telephone numbers of contacts can be found on the Internet on our homepage under www.walther-praezision.de "Service / Customer service".

List of Contents

1	<u>List of Contents</u>	
1	LIST OF CONTENTS	3
2	GENERAL.....	4
3	WARRANTY.....	5
4	SAFETY INSTRUCTION	6
5	PRODUCT DESCRIPTION OF THE FLUIDIC MULTI-COUPLING	7
5.1	INTENDED USE	7
5.2	TECHNICAL DATA	7
6	INSTALLATION INSTRUCTION.....	8
7	OPERATING INSTRUCTION	9
7.1	COUPLING PROCESS	9
7.2	DECOUPLING PROCESS.....	12
8	MAINTENANCE INSTRUCTION.....	13
8.1	MAINTENANCE AND FUNCTIONAL TEST.....	13
8.1.1	<i>Maintenance includes following items:.....</i>	<i>13</i>
8.1.2	<i>Functional test includes following items:</i>	<i>13</i>
9	TEST.....	14
10	LUBRICATION.....	15
11	STORAGE	16
12	SHUT-DOWN.....	17
13	ORDER NUMBER CODE	18
14	INDEX.....	19

2 General

This manual contains all regulations for operation, commissioning and maintenance of the fluidic multi-coupling.

All information and notes in this operating instruction were collated while taking into consideration the valid regulations, the current engineering related status of development as well as our many years of experience and acquired knowledge.

Translations of this operating instruction were also produced according to the best of knowledge.

However, we cannot assume liability for any translation errors.

The German version provided for this operating instruction is considered the authoritative version.

The actual scope of delivery can deviate from the explanations and graphic representations described herein under certain circumstances, e.g. in the case of special designs, utilization of additional order options or because of state-of-the-art technical alterations.

If you have any questions, please contact the manufacturer.

- ☞ This operating instruction must be read carefully before starting work on or with the equipment, in particular before commissioning!
The manufacturer assumes no liability for damage or faults arising from non-compliance with the instructions in this operating instruction.

The operating instruction must be kept directly with the equipment and be accessible to all persons who work on or with the equipment.

It is not permitted for the operating instruction to be passed to third parties and if applicable this will incur damage compensation.

All other rights reserved.

Before commissioning the device must be checked for being not defective and its technically perfect function.

The German version is the original.

We reserve the right to make technical alterations to the product within the context of improving the usage properties and further development.

The operating instruction remains our property.

Any reproduction, use by or communication to third parties incurs a penalty and will be pursued by court action (copyright law against unfair competition, BGB [German Civil Code]).

All rights reserved in the case of a patent award (Paragraph 7, Section. 1 of the patent law - PG) or entry as a patented design (Paragraph 5, Section 4 of the patented design law - GMG).

3 Warranty

The warranty conforms to:

the “General Conditions for Delivery and Capacity” of C.K. Walther GmbH & Co. KG of the state which was valid at the date of the purchase contract and

the regulations agreed in the purchase contract.

Wearing parts are generally excluded from the warranty.

Typical wearing parts of products from company C.K. Walther GmbH & Co. KG are for example:

- seals
- hoses which are exposed to a regular alternating bending load or torsional stress

Also components which normally do not wear under the estimated conditions (ambient and operational conditions) can transform into wearing parts if the described product is not operated to the agreed conditions or if technical demands of the operating instructions are disregarded.

Safety Instruction

4 Safety Instruction

Using this fluidic multi-coupling does not release the customer from his obligation to comply with the pertinent work safety regulations e.g. operational safety ordinances, etc. The duty to take due care by the operator of the fluidic multi-coupling includes planning measures to ensure proper operation and monitoring their implementation.

Hazard notes

If the wrong product has been selected or if there is improper use or maintenance has been omitted, then hazards arise and personal injuries and material damage can occur from:

- Hazardous emission of fluid or individual particles/coupling parts
- Function impairments of connected systems or tools
- The metal parts of coupling and adaptor are not thermally protected. You can be burned if you touch these parts at high media temperatures. According to the ambient temperature valve lever and ring grip can also become unbearably hot. For that reason suitable, sufficiently long protective gloves should be worn.

The operator must in particular make sure that

- The fluidic multi-coupling is only used according to the intended purpose.
- The fluidic multi-coupling is only operated in a perfect, functioning condition.
- The operating instruction is always in a legible condition and is available in its entirety to operating personnel.
- The operating personnel are sufficiently acquainted with the working method and the safety notes for the fluidic multi-coupling.
- The fluidic multi-coupling is sent to our factory for repair work.
- During operation of the fluidic multi-coupling, no safety devices are removed and/or deactivated.
- Before installing or dismantling the fluidic multi-coupling, you have made sure that the coupling has not been pressurized.

After completing assembly and installation work and before commissioning the fluidic multi-coupling, observe the following points:

Check once again that all screw connections are securely fitted.

Before commissioning the fluidic multi-coupling, a function test must be carried out (see maintenance and function test).

Product description of the coupling

5 Product description of the fluidic multi-coupling

Coupling connection consists of:

- Fluidic multi-coupling free half 1-90405-1-.....-...-Z13-..
- Fluidic multi-coupling fixed half 1-90405-4-.....-...-Z10-..

Using the coupling connection described here, 4 individual cables can be linked. The number of cables to be linked may vary according to the different inserts.

In case that both coupling halves are not connected they should be protected against external dirt and/or damages if required.

5.1 Intended use

- Fluidic multi-coupling is only used as connection of lines.
- Connection and disconnection process is carried out by hand.
- Fluidic multi-coupling is especially suitable for the following media/applications:
 - air
- For all other possible applications, Walther-Präzision should be consulted.

5.2 Technical data

- Working pressures of coupling depend on materials of individual parts.

Working pressure static:

per element: 10 bar

- The fluidic multi-coupling is not determined for any types of use and technical values other than those listed here.
- Safe operation is not guaranteed if the fluidic multi-coupling is used contrary to its intended use and technical values
- The operator of the fluidic multi-coupling is responsible for all personal injuries or material damage that occur from non-intended use and disregard of the technical values; the manufacturer assumes no responsibility in these cases.

Installation instruction

6 Installation Instruction

Install the fluidic multi-coupling into the network in due consideration of the general accident prevention regulations, so that:

- an error-free operation according to the operating instructions is guaranteed.
- exterior damage to the unit and to all movable parts is ruled out.
- Before installing the through type coupling and the adaptor to the piping system, make sure that the piping system has been sufficiently flushed/blown or cleaned.



After completing the installation work, perform a function test both depressurised and under working pressure, as described in the operating instructions.

Operating Instruction

7 Operating Instruction

In order to avoid critical injuries of the staff and damage at the fluidic multi-coupling during operation, fluidic multi-coupling may be only used for the stated applications.

Functional Description of the coupling

7.1 Coupling process

Before every couple cycle a visual check of fluidic multi-coupling and adaptor is to be carried out. In case of recognizable, visible damage or deformations damaged parts are to be exchanged.

1. For the purpose of coupling, the locking lever must be in the correct starting position.

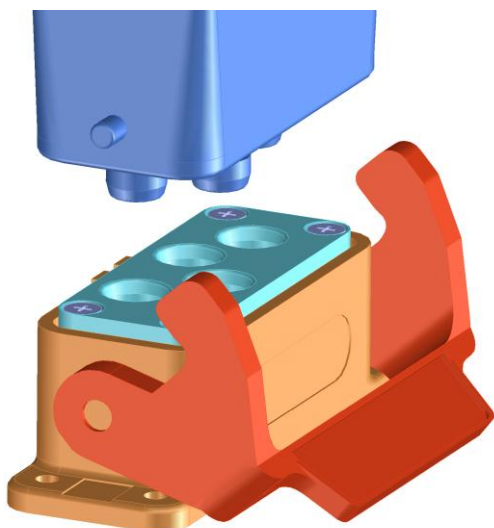

right

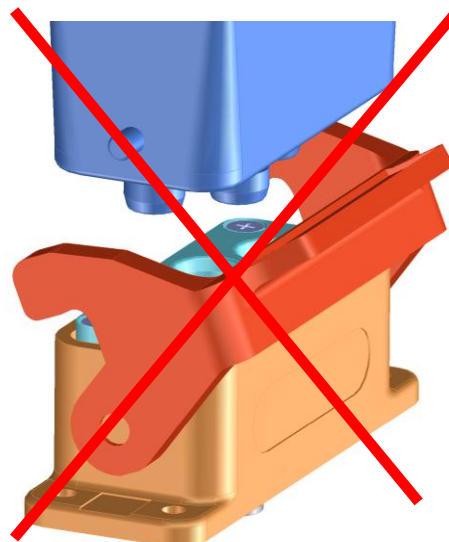

wrong

Operating Instruction

2. Fit the loose half to the fixed half. There is now a small gap between the loose and the fixed halves. The final coupling and locking process is carried out by the locking lever. To lock, the lever is pulled towards the loose half as shown in the pictures.

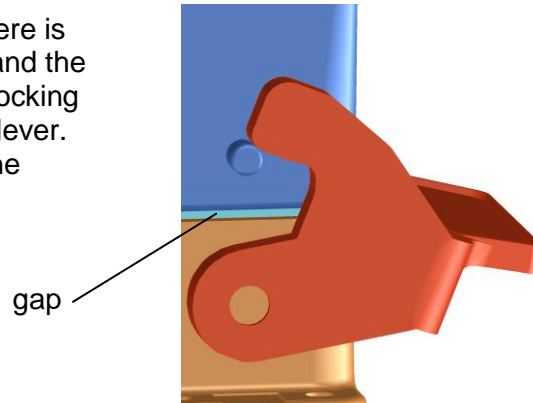

3. When coupling, gentle force must be applied to counteract the friction between the lever and the cam. At the end of this movement, the lever snaps into the end position.



Do not hold the lever between finger and thumb (see picture on this page).

Fingers slipping off or slight bruising of the fingertips may occur.

Pull the lever up only with the ball of the hand or with the fingers (see pictures on subsequent pages).

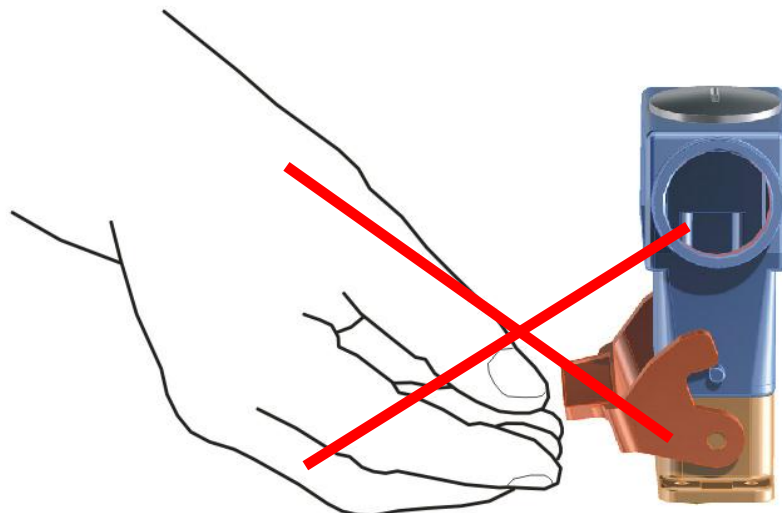

Operating Instruction

Pull up with the ball of
the hand

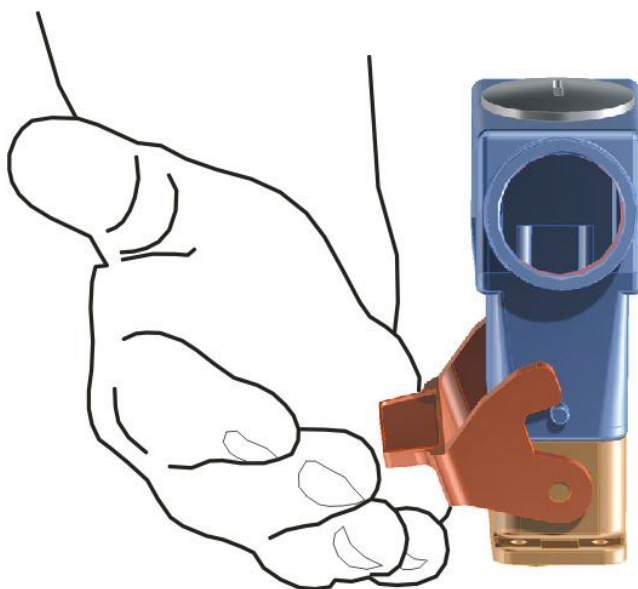

Use fingers to pull up
from below

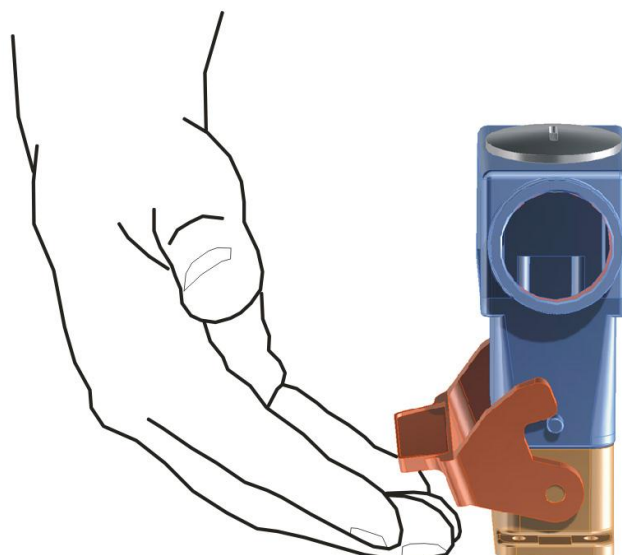

Operating Instruction

7.2 Decoupling process

When decoupling the Fluidic multi-coupling halves, the locking lever is pushed towards the fixed half.



**Do not hold the lever between finger and thumb
(see 1st picture on this page).**

**Fingers slipping off or slight bruising of the
fingertips may occur.**

**Push the lever down only with the ball of the hand
(see 2nd pictures on this page).**

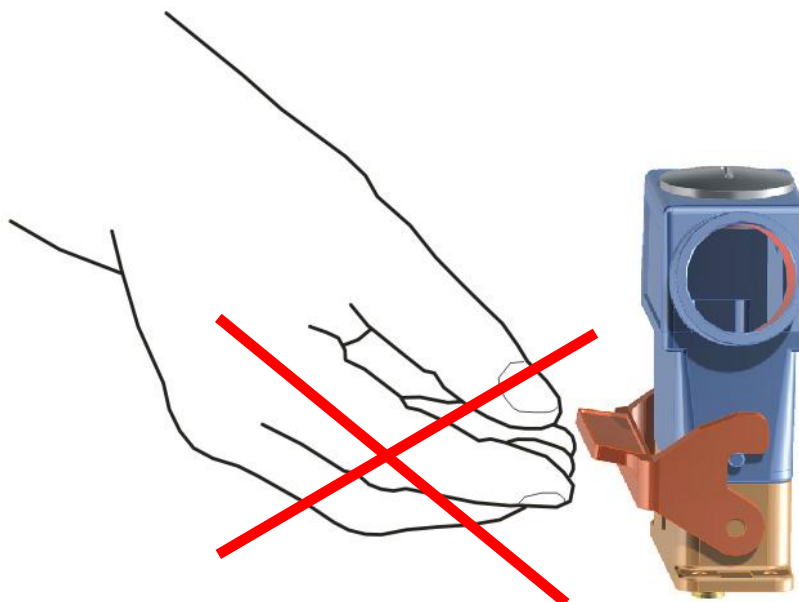

Push down with the
ball of the hand



Wartung und Funktionsprüfung

8 Maintenance Instruction

Preventive maintenance measures

WALTHER fluidic multi-coupling is to be operated in such a manner that external damages to elements and all moving parts are avoided.

8.1 Maintenance and functional test

In order to always guarantee function of the fluidic multi-coupling and hence safety of operator, a maintenance and functional testing must be made in appropriate periods of time depending on operating conditions.

In order to minimize operating forces and to extend service life of the fluidic multi-coupling we recommend to slightly grease plug surfaces (see item 10.0).

8.1.1 Maintenance includes following items:

- A visual inspection of fluidic multi-coupling free half and fluidic multi-coupling fixed half regarding damage and contamination has to be made.
- Dirt at the functional area (sealing area, operating elements) which is easily accessible from outside should be removed by simply wiping-off.

If there are damaged, torn or corroded parts, fluidic multi-coupling must be dismantled and returned to manufacturer for repair.

If worn or embrittled seals are found or if there is extreme dirt, the customer can decide whether he returns fluidic multi-coupling unit to the manufacturer's factory or whether he repairs himself.

8.1.2 Functional test includes following items:

As described in the operating instruction, fluidic multi-coupling is several times connected, pressurized and then disconnected.

In doing so, the following has to be observed:

- Connection and disconnection process must be absolutely smooth.
- Fluidic multi-coupling must be absolutely leak-proof in connected and disconnected state.

If there are damaged, torn or corroded parts, fluidic multi-coupling must be dismantled and returned to manufacturer for repair.

If worn or embrittled seals are found or if there is extreme dirt, the customer can decide whether he returns the fluidic multi-coupling unit to the manufacturer's factory or whether he repairs himself.

Please note !

If the fluidic multi-coupling is repaired by the customer themselves, a pressure and/or leak test must be performed in any case. The sequence and extent of this test is described in section "Test".

Please note !

The manufacturer's warranty shall not apply to the end product if it is repaired by other than the manufacturer, Walther-Präzision.

9 Test

(Extract from the test instructions QM-PA 2.0 of the Walther-Präzision QM system)

Description:

The coupling is tested by means of an immersion test according to the following values.

Series low pressure	test pressure
90405-Z13_Z10	2 bar absolut

- Test setup and test procedure

Test 1: coupling and adaptor connected

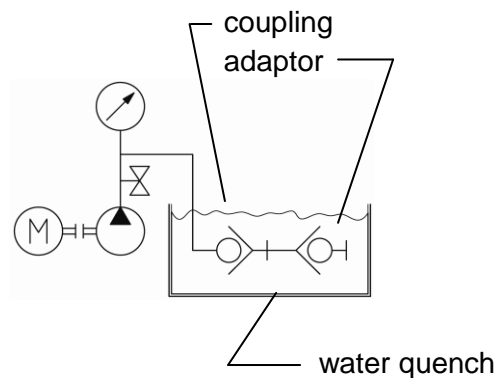

- Notes and remarks:

The dwell time per test is 10 seconds.

There must not be any bubbles during the 10 seconds dwell time.

After testing the coupling must be dried with hot air as soon as possible

(recommended: 45 – 55 °C, approx. 30 min with air stream, up to 2 hours with stagnant air, depending on the device).

- Documentation:

Please document the test pressure, test medium and name/date of each test.

10 Lubrication

In order to minimize operating forces and to extend service life of the fluidic multi-coupling we recommend to slightly grease plug surfaces.

Lubrication is to be carried out with greases which **do not** tend to become resin.



Caution !

The selection of the grease is to be suited to the sealing quality and the medium (e.g.: oxygen) in view of the compatibility.

11 Storage

The fluidic multi-coupling must be stored in such a way that no damages can occur at the fluidic multi-coupling.

The storage conditions of the fluidic multi-coupling must comply with the guidelines for the seals as these can change in properties due to improper storage.

The following items must be kept:

- The fluidic multi-coupling must be stored dry.
- To safely conserve the seals and that means also the fluidic multi-coupling they should not be stored under the effect of daylight.
- For protection against oxygen the seals and also the fluidic multi-coupling shall be stored into the packing.

12 Shut-down

At the end of the service life the fluidic multi-coupling or its components have to be disposed non-polluting and according to the legal regulations.

For that the local public or private disposal societies should be taken.

13 Order number code

1.	2.	3.	4.	5.	6.	7.	8.	9.
☒	☒☒	☒☒☒	☒	☒☒☒☒☒	☒☒	☒	☒☒☒	☒☒
☒	☒☒	☒☒☒	☒	☒☒☒☒☒	☒☒☒☒	☒☒☒☒	☒☒☒	☒☒

1. Subject group
2. Series
The information regarding the series comprises either two letters or two numbers.
3. Nominal size / Nominal bore
It is rounded up or down to one. The information can be numerical as well as alphanumerical.
4. Product type or design type
5. Connection design
6. Material design:
xx-x and xxxx possible
7. Material design (seal design):
xx-x and xxxx possible
8. Y or Z design
9. Additional equipment

14 Index

A		Hazardous emission6
According to intended purpose..... 6		<i>I</i>
Acquired knowledge..... 4		Implementation6
Adaptorl..... 6		Improvement4
Alterations..... 4		Index..... 19
Assembly 6		Inspection.....2
B		Installation Instruction8
Betriebsdruck 7		Intended use7
C		<i>L</i>
Commissioning 4, 6		Legible condition6
connected..... 7		Liability4
connection..... 7		List of Contents3
Connection process 9		Lubrication 15
Contact 2		<i>M</i>
coupling..... 6		Maintenance2, 4, 6
Customer care 2		Maintenance and functional test..... 13
D		Maintenance Instruction..... 13
Damage..... 4, 6		Manual4
Damage compensation..... 4		Media temperatures6
daylight..... 16		<i>N</i>
Disposal societies 17		Not operated to the agreed condition.....5
Disregard 7		<i>O</i>
dry..... 16		Operating instruction5
E		Operating Instruction.....9
Entkuppelvorgang 12		Operation2
Equipment 4		Operational safety ordinances.....6
Experience 4		operator2, 6, 13
F		Order number code..... 18
Faults 4		Original4
Fluid 6		<i>P</i>
Fluidic multi-coupling .4, 6, 7, 8, 9, 13, 15, 16, 17		packing 16
Function..... 6		particular6
Function test..... 6		Perfect, functioning condition6
Functionality..... 2		Performance capability2
G		pressurized.....6
General 4		Product description.....7
guarantee 13		Property4
H		Protective gloves.....6
Hazard notes 6		<i>Q</i>
		quality 15

R

Regulations	4
Reliability	2
remarks.....	14
Repair work	6
responsible	7

S

Safety.....	2
Safety devices.....	6
Safety Instruction	6
Scope of delivery	4
Screw connections.....	6
service.....	2, 13, 15
Service	2
Shut-down	17
Special designs.....	4
Specialists	2
Status of development	4
Storage	16
Systems.....	2, 6

T

Technical data	7
Technical equipment.....	2
Technical values	7
Test.....	14
Thermally	6
Tools.....	2, 6
Translation errors.....	4
Types of use	7

U

Use	2
-----------	---

V

Version	4
---------------	---

W

Work safety regulations	6
Working method	6
Wrong product selection	6