

## Operating Instruction english

revision	A
date	28.05.2015
author	NH

This operating instruction is not  
subject to the updating

## High temperature coupling for heat transfer oil up to 270°C (310°C) DN 19

**1-11-019-0-WR533-AAAI-HG**

**ident no 38797**

**1-11-019-0-WR533-AAAI**

**ident no 42558**

**1-11-019-0-WR533-AAAH -HG**

**ident no 75686**

**1-11-019-0-WR533-AAAH**

**ident no 76202**

**1-11-019-2-WR533-AAAA**

**ident no 38256**

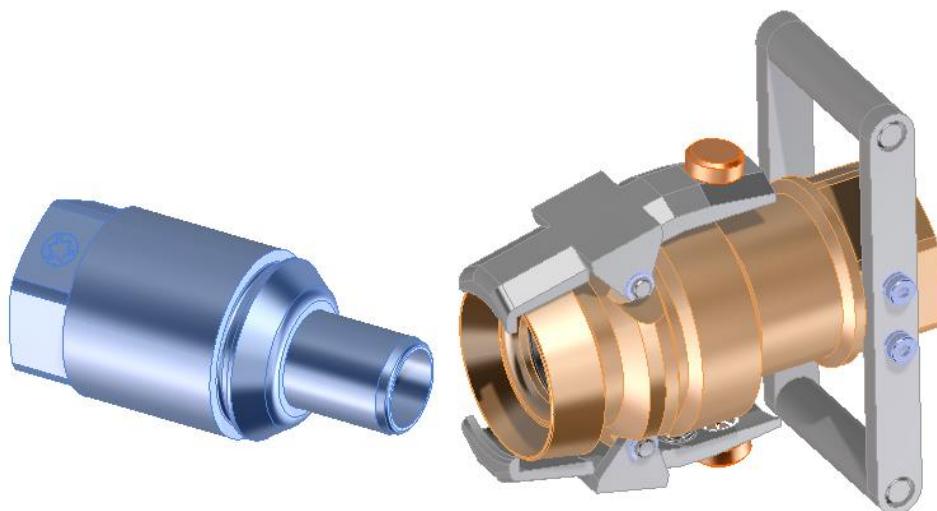

This coupling is a quality product, in which special attention has been paid to high functionality, ease of operation, safety and reliability. As an item of technical equipment this coupling is intended for use in the commercial, industrial area and for operators, who have been trained by specialists in the handling of technical systems / tools.

**Customer care:**

As part of our individual customer care we will be happy to assist you in questions relating to use and operation and on any problems encountered.

**Service and maintenance:**

In order to maintain the high technical performance capability and reliability of your coupling over many years, we recommend regular inspection and maintenance.

We can thereby offer you optimum support by our Customer Service department and the conclusion of a service and maintenance contract. Please ask for a quotation.

WALTHER-PRÄZISION  
Carl Kurt Walther GmbH & Co. KG  
Westfalenstraße 2  
42781 Haan

PO Box 42 04 44  
42404 Haan  
Germany

telephone: +49 (0) 2129 / 567-0  
telefax: +49 (0) 2129 / 567-450

E-Mail: [info@walther-praezision.de](mailto:info@walther-praezision.de)  
Internet: [www.walther-praezision.de](http://www.walther-praezision.de)

**Contact:**

Application technology and service

Holger R. Figge

telephone: +49 (0) 2129 / 567-591  
telefax: +49 (0) 2129 / 567-590  
mobile: +49 (0) 162 / 2090100  
e-mail: [hfigge@walther-praezision.de](mailto:hfigge@walther-praezision.de)

Further addresses and telephone numbers of contacts can be found on the Internet on our homepage under [http://www.walther-praezision.de/english/info\\_kontakt/service..](http://www.walther-praezision.de/english/info_kontakt/service..)

## Table of Contents

### 1 Table of Contents

<b>1</b>	<b>TABLE OF CONTENTS.....</b>	<b>3</b>
<b>2</b>	<b>GENERAL.....</b>	<b>5</b>
<b>3</b>	<b>SAFETY INSTRUCTIONS .....</b>	<b>6</b>
3.1	GENERAL INSTRUCTIONS .....	6
3.1.1	General:.....	6
3.1.2	Precautions:.....	6
3.1.3	Distribution:.....	6
3.1.4	Responsibility of user:.....	7
3.1.5	Further questions: .....	7
3.2	INSTRUCTIONS FOR THE SELECTION OF A QUICK COUPLING.....	7
3.2.1	Pressure:.....	7
3.2.2	Compatibility of fluids: .....	7
3.2.3	Temperature:.....	7
3.2.4	Construction size: .....	7
3.2.5	Pressurized connection or disconnecton: .....	8
3.2.6	Environment: .....	8
3.2.7	Locking means:.....	8
3.2.8	Mechanical loads: .....	8
3.2.9	Specifications and standards:.....	8
3.2.10	Vacuum:.....	8
3.2.11	Fire resistant fluids:.....	8
3.2.12	Radiation heat: .....	8
3.2.13	Welding and brazing:.....	8
3.3	INSTRUCTIONS FOR CORRECT INSTALLATION .....	9
3.3.1	Pre-installation inspection:.....	9
3.3.2	Quick couplings or (spare) parts of other manufacturers: .....	9
3.3.3	Fitting installation: .....	9
3.3.4	Protection caps and plugs: .....	9
3.3.5	Coupling location:.....	9
3.4	MAINTENANCE INSTRUCTIONS FOR QUICK COUPLINGS.....	9
3.4.1	Visual inspection of quick couplings:.....	9
3.4.2	Further visual inspections:.....	10
3.4.3	Functional test:.....	10
3.4.4	Replacement intervals:.....	10
<b>4</b>	<b>WARRANTY.....</b>	<b>11</b>
4.1	GENERAL .....	11
4.2	REPLACEMENT PARTS .....	11
<b>5</b>	<b>PRODUCT DESCRIPTION .....</b>	<b>12</b>
5.1	INTENDED USE .....	12
5.2	TECHNICAL DATA.....	12
<b>6</b>	<b>COMPONENTS OF THE ASSEMBLY GROUPS .....</b>	<b>13</b>
<b>7</b>	<b>INSTALLATION MANUAL .....</b>	<b>14</b>

## Table of Contents

<b>8</b>	<b>OPERATING INSTRUCTIONS .....</b>	<b>15</b>
8.1	COUPLING PROCESS .....	15
8.2	DECOUPLING PROCESS .....	16
<b>9</b>	<b>MAINTENANCE AND FUNCTION TEST.....</b>	<b>17</b>
9.1	MAINTENANCE: .....	17
9.2	FUNCTIONAL TESTING:.....	18
9.3	1-11-019-0-WR533-AAAI (HG) .....	19
9.4	1-11-019-0-WR533-AAAH (HG).....	20
9.5	1-11-019-2-WR533-AAAA.....	21
<b>10</b>	<b>TEST.....</b>	<b>22</b>
10.1	IMMERSION TEST .....	22
10.1.1	<i>Test setup of the connected state (schematic view) .....</i>	22
10.1.2	<i>Test procedure .....</i>	22
10.1.3	<i>Test disconnected.....</i>	23
10.1.4	<i>Test setup of the disconnected state (schematic view).....</i>	23
10.1.5	<i>Test procedure .....</i>	23
10.1.6	<i>Test result.....</i>	23
10.2	PRESSURE TEST.....	24
10.2.1	<i>Test setup of connected state (schematic view) .....</i>	24
10.2.2	<i>Test procedure .....</i>	24
10.2.3	<i>Test disconnected.....</i>	25
10.2.4	<i>Test setup of the disconnected state (schematic view).....</i>	25
10.2.5	<i>Test procedure .....</i>	25
10.2.6	<i>Test result.....</i>	26
10.3	DOCUMENTATION .....	26
<b>11</b>	<b>STORAGE .....</b>	<b>27</b>
<b>12</b>	<b>SHUT-DOWN.....</b>	<b>27</b>
<b>13</b>	<b>INDEX.....</b>	<b>28</b>

## 2 General

This operating instruction contains all regulations for operation, commissioning and maintenance of the coupling.

All information and notes in this operating instruction were collated while taking into consideration the valid regulations, the current engineering related status of development as well as our many years of experience and acquired knowledge.

Translations of this operating instruction were also produced according to the best of knowledge. However, we cannot assume liability for any translation errors. The German version provided for this operating instruction is considered the authoritative version.

The actual scope of delivery can deviate from the explanations and graphic representations described herein under certain circumstances, e.g. in the case of special designs, utilization of additional order options or because of state-of-the-art technical alterations. If you have any questions, please contact WALTHER-PRÄZISION.



This operating instruction must be read carefully before starting work on or with the equipment, in particular before commissioning! WALTHER-PRÄZISION assumes no liability for damage or faults arising from non-compliance with the instructions in this operating instruction.

The operating instruction must be kept directly with the equipment and be accessible to all persons who work on or with the equipment.

It is not permitted for the operating instruction to be passed to third parties and if applicable this will incur damage compensation. All other rights reserved.

Before commissioning the device must be checked for being not defective and its technically perfect function.

The German version is the original.

We reserve the right to make technical alterations to the product within the context of improving the usage properties and further development.

The operating instruction remains our property.

Any reproduction, use by or communication to third parties incurs a penalty and will be pursued by court action (copyright law against unfair competition, BGB [German Civil Code]). All rights reserved in the case of a patent award (Paragraph 7, Section. 1 of the patent law - PG) or entry as a patented design (Paragraph 5, Section 4 of the patented design law - GMG).

## Safety instructions

### 3 Safety instructions



#### **WARNING / ATTENTION:**

Wrong choice or wrong and improper usage of quick couplings and their accessories may result in damages to property and persons, partly even with fatal outcomes.

Possible consequences of wrong choice or wrong handling can be as follows:

- Coupling or other construction parts with high risk potential may fly around uncontrollably.
- Escape of hydraulic fluids under high pressure and with high speed.
- Collisions with moving, sagging or dropping construction parts after downfall of the hydraulic cycle.
- Dangerous swing out of the hydraulic hose (whipping effect).
- Explosion or inflammation of the used liquids.
- Physical contact with liquids which can be very hot, very cold, toxic or for other reasons dangerous.
- Squinting or explosion of solvents or other inflammable liquids which are used in chemical processes.

Before selection and usage of a quick coupling by WALTHER-PRÄZISION or the corresponding accessories, the following instructions must be read and obeyed.

#### 3.1 General Instructions

##### 3.1.1 General:

The directives start with choice and handling (installation, connection/disconnection and maintenance) of WALTHER-PRÄZISION quick couplings. This brochure is to be regarded as an additional safety advice and shall be applied in combination with all other information, instructions etc. by WALTHER-PRÄZISION which refer to the respective products and their accessories.

##### 3.1.2 Precautions:

Quick couplings may break down unexpectedly for several reasons. Please design all systems and plants in a way that a downfall of the quick coupling or the hose cannot result in damages to property and persons.

##### 3.1.3 Distribution:

Please give a copy of these safety instructions to all persons who are tasked with the selection or handling of quick couplings.

It is imperative that you read and understand this safety instructions and product-specific publications before selecting or installing a coupling.

## Safety instructions

---

### 3.1.4 Responsibility of user:

Due to the various functionality and numerous possible applications of quick couplings, WALTHER- PRÄZISION with its distributor network cannot guarantee that a special coupling is suitable for each specific application. This safety brochure does not analyse all technical details which are imperative for the selection of a coupling.

After own analysis, the user is responsible for:

- the final selection of his quick coupling;
- the compliance with the demands of the end user as well as safety against damages to property and persons;
- the precautions which are mandatory for the application of quick couplings.

### 3.1.5 Further questions:

If you have any questions or wish further information, please refer to your supplier or directly to WALTHER-PRÄZISION. Contact opportunities are mentioned in the web or for example in the respective catalogues and product information.

## **3.2 Instructions for the selection of a quick coupling**

### 3.2.1 Pressure:

The selection of a quick coupling has to be made in such a way that the maximum permissible working pressure of the coupling is higher or equal to the system pressure. Pressure peaks in the system, which exceed the working pressure, shorten the service life considerably. Never interchange burst pressure or other pressure details with the working pressure and do not apply the burst pressure as working pressure.

### 3.2.2 Compatibility of fluids:

The selection of a quick coupling has to be made in such a way that the compatibility between the material of the coupler body and the sealing is guaranteed. Detailed information to compatibility is mentioned in the media table in your WALTHER-PRÄZISION coupling catalogue.

### 3.2.3 Temperature:

Be certain that the fluid and ambient temperature never exceed the permissible values for the coupling, neither in downtime nor in ongoing operation. Ensure appropriate safety measures. Use hand protection when connecting or disconnecting quick couplings which are still heated or cooled by the conducted media or environment.

### 3.2.4 Construction size:

Transmission of power by means of pressurized liquid varies with pressure and rate of flow. The size of the quick couplings and other components of the system must be adequate to keep pressure losses to a minimum and avoid damage due to heat generation or excessive fluid velocity.

## Safety instructions

---

### 3.2.5 Pressurized connection or disconnecton:

If connecting or disconnecting under pressure is mandatory, use only quick couplings designed for that purpose. The rated operating pressure of a quick coupling may not be the pressure at which it may be safely connected or disconnected.

### 3.2.6 Environment:

Environmental conditions which lead to premature wear or downfalls are for example ultraviolet radiation, ozone, mildew, water, salt water, chemicals or air pollution. Care must be taken to ensure that quick couplings can be stored and applied under the given circumstances.

### 3.2.7 Locking means:

Quick couplings with ball locking can disconnect unintentionally when the hose is dragged over obstructions or if the sleeve is bumped or moved enough to cause disconnection. Sleeves equipped with flanges to provide better gripping for oily or slippery hands and with a breakaway device should not be used under the a. m. operation conditions. For these applications, quick couplings should be equipped with a safety locking.

### 3.2.8 Mechanical loads:

External forces, for example tensile or transverse force as well as vibrations can shorten considerably the service life of a quick coupling or lead to premature downfall. Therefore, untypical applications require according tests.

### 3.2.9 Specifications and standards:

When selecting quick couplings, specifications of government, industry and WALTHER-PRÄZISION must be followed.

### 3.2.10 Vacuum:

Not all quick couplings are suitable or recommended for vacuum applications. Couplings for usage in vacuum must be selected to ensure that they meet the requirements of the special operating conditions and pressures.

### 3.2.11 Fire resistant fluids:

Some fire resistant fluids require different sealing material than the used standard.

### 3.2.12 Radiation heat:

Quick couplings can be heated by radiation heat (for example from liquid metal) until the sealing materials and even the coupler body are destructed.

### 3.2.13 Welding and brazing:

Heating of zinc plated parts (coupler body) above 232 °C by welding or brazing can generate dangerous gases which may damage, among others, the coupling sealings.



## Safety instructions

---

### **3.3 Instructions for correct installation**

#### **3.3.1 Pre-installation inspection:**

Before installation of a coupling, it is necessary to inspect it visually and check if the material of the coupling and the seals meet the specifications. Before final mounting, both coupling halves should be connected and disconnected on trial.

#### **3.3.2 Quick couplings or (spare) parts of other manufacturers:**

Please use exclusively original (spare) parts by WALTHER-PRÄZISION to ensure the safe operation of your quick couplings by WALTHER-PRÄZISION. We expressly note that no compensation will be accepted for damages resulting from the use of (spare) parts or from combinations of couplings with (spare) parts of other manufacturers.

#### **3.3.3 Fitting installation:**

When connecting a quick coupling, use thread sealant, liquid seals or a combination of both between cylindrical and conical threads. Make sure that the seals are compatible with the media to be transported. To avoid system soils, it is recommended to use liquid seals instead of a sealing tape. Use the provided screw driver during the installation. Never use a pipe wrench or a vario key as thread seals in the coupling can be damaged and other elements of the coupling can be affected. Excessive tightening torques can destroy the threads or may lead to bursting of the thread block.

#### **3.3.4 Protection caps and plugs:**

While the coupling halves are disconnected, it is recommended to prevent the entry of soil particles and other contaminations by the use of protection caps and protection plugs.

#### **3.3.5 Coupling location:**

Locate the quick couplings where they can be reached for connection and disconnection without endangering the operator to skid, to fall, to be sprayed or to get in contact with hot, moving parts.

### **3.4 Maintenance instructions for quick couplings**

Even at proper selection and installation, the service life of a quick coupling can be significantly reduced by poor care and maintenance. Frequency of maintenance should be adapted to operating conditions and risk potential. A maintenance program must be established and followed by the user and should contain the following items:

#### **3.4.1 Visual inspection of quick couplings:**

Any of the following failures require an immediate shut down and replacement of the quick coupling:

- cracked, damaged or corroded quick coupling parts
- leakages at the fitting, valve or coupler body
- broken coupling mounting hardware (especially breakaway clamps)

## Safety instructions

---

### 3.4.2 Further visual inspections:

- leaking seals
- soils at the coupler body or in the interface area between both coupling halves
- clamps, guards and shields
- fluid level, fluid characteristics and system ventilation

### 3.4.3 Functional test:

Run up the system at maximum operating pressure and check for possible malfunctions and tightness. Personnel must avoid potential hazardous areas while testing and using the system.

### 3.4.4 Replacement intervals:

Specific replacement intervals must be adapted to empirical values and requirements of government and industry.

They also depend on operating safety, downtimes and default risk.

## 4 Warranty

### 4.1 General

The warranty is in accordance with:

The regulations agreed upon in the purchase contract and

The "General terms and conditions for delivery and service" of WALTHER-PRÄZISION using the version valid at the time the purchase contract came into force.

Generally excluded from the warranty are consumables.

Typical consumables in products from WALTHER-PRÄZISION are, for example:

- Seals
- Springs
- Electro plug contacts
- Electrical cables and hoses which are subject to regular alternating bending or torsional stresses.

Components that are not normally subject to wear under the conditions to be expected (environmental and usage) may become consumables if the described product is not operated according to the intended purpose or is operated with a disregard for the specifications in the operating instructions.

For example, electrical cables with sheathing that has been destroyed by extreme exposure to welding sparks would not fall under the warranty.

In addition, wear to other components caused by unusual environmental conditions, not expressly coordinated with WALTHER-PRÄZISION, for example, high temperatures, dusts with an abrasive effect, high humidity or corrosive vapours and gases are not covered by the warranty.

Cycle, time or load dependant specifications for the replacement of certain components of the described product within the framework of maintenance are not warranty-relevant durability statements, they are instead recommendations designed as preventive maintenance to avoid standstill times during production.

### 4.2 Replacement parts

#### Warning!

**The use of non-Walther-parts can cause personal injuries, death as well as material damage.**

Only original parts from WALTHER-PRÄZISION are to be used.  
These are to be installed according to their intended purpose.

When using third-party items or parts that have not been approved by WALTHER-PRÄZISION, all warranties, guarantees and service claims are voided without notification.

## Product description

### 5 Product description

The combinations of materials/design and seal are to be responsibly selected by the operator/ordering-party/customer/planner in accordance with their media/pressure and flow combination.

The coupling connection comprises:

self sealing coupling element	1-11-019-0-WR533-AAAI(HG)	for max. 310°C
self sealing adaptor element	1-11-019-2-WR533-AAAA	
self sealing coupling element	1-11-019-0-WR533-AAAH(HG)	for max. 270°C
self sealing adaptor element	1-11-019-2-WR533-AAAA	

#### 5.1 Intended use

- The coupling acts only to connect two lines.
- The two coupling halves should only be coupled and decoupled in an unpressurized state.
- The locking is carried out using the locking levers.
- The operation is carried out without any special tools or aids (the prescribed protective gear must still be worn).
- Alternatively, the use of a bleed-off valve in the coupling plate is possible, as long as no safety valve is used in the system or feed line.
- The coupling is particularly suitable for the following media/uses:
  - **Heat transfer oil**
- For all other media, consult Walther Präzision.

#### 5.2 Technical Data

- For thread connections, when specify the operating pressures, the highest permitted operating pressure of the connection are to be taken into account.

##### Operating pressure connected and disconnected (standard):

##### **CAUTION**

**For normed threaded connections, when specifying the operating pressure, the highest permitted operating pressure of the connection must be taken into account!**

**Differing higher or lower operating pressures are possible according to material characteristics or the connection.**

**This operating pressure is to be taken from the project-specific documentation.**

##### Operating pressure

Steel                                      Coupled        =        16 bar

Sealing                                      10<sup>-3</sup> mbar l/s

- The coupling is not designed for purposes and with technical values other than the ones listed in the product description .
- If the coupling is used for a purpose other than the intended or not in accordance with the technical values, safe operation cannot be ensured.
- The operator is responsible, not the manufacturer, for all personal and property damage resulting from unintended uses and violations of the technical values.

## Components of the assembly groups

---

### **6 Components of the assembly groups**

1-11-019-0-WR533-AAAI-HG (ident no 38797) is version D  
1-11-019-0-WR533-AAAI (ident no 42558) is version D  
1-11-019-0-WR533-AAAH -HG (ident no 75686) is version A  
1-11-019-0-WR533-AAAH (ident no 76202) is version D  
1-11-019-2-WR533-AAAA (ident no 38256) is version A

**Only original parts of WALTHER-PRÄZISION are to be used, the assembly of which has to be carried out according to the intended purpose.**

**The general terms according to the chapters General, Warranty, Safety instructions, Storage, Lubrication and Shut-down in the text documentation for the applications are applicable.**

### 7 Installation manual

The self-sealing coupling is to be installed, whilst observing the general accident prevention regulations, in such a way into a line network that :

- Trouble-free operation in accordance with the operating instructions is ensured.  
This means that during installation or removal of the coupling side and the adaptor side to the client structure, only the hexagonal element on the client connection may be used to tighten or loosen the component.
- The screw attachment to the client connection must follow the appropriate technical regulations.
- The self-sealing coupling is located primarily on the network side and the self-sealing adaptor primarily on the consumer side .
- External damages to the unit and all moving parts are excluded.

Before the self-sealing coupling and adaptor are installed in a pipeline network it must be ensured that the pipeline network has been rinsed/blown out or cleaned sufficiently.



**After completing the assembly work, a function test must be carried out according to the operating instruction, both in depressurized state and under operating pressure.**

## Operating Instruction

### 8 Operating instructions

In order to prevent potentially fatal injuries to personnel and damage to the couplings when operating, these may only be used under the conditions set out under Point 5 (product description).

#### 8.1 Coupling process

Remove the dust cap on the self-sealing or through-type adaptor.

Hold the self-sealing or through-type coupling with one hand, and position it with the axial centred, on the self-sealing or through-type adaptor.

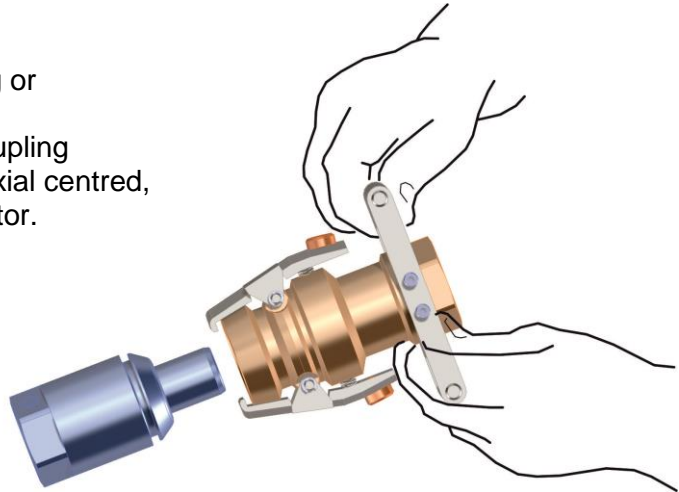

Slide the self-sealing or through-type coupling onto the self-sealing or through-type adaptor. In doing so, both hand levers slide along the inclines,

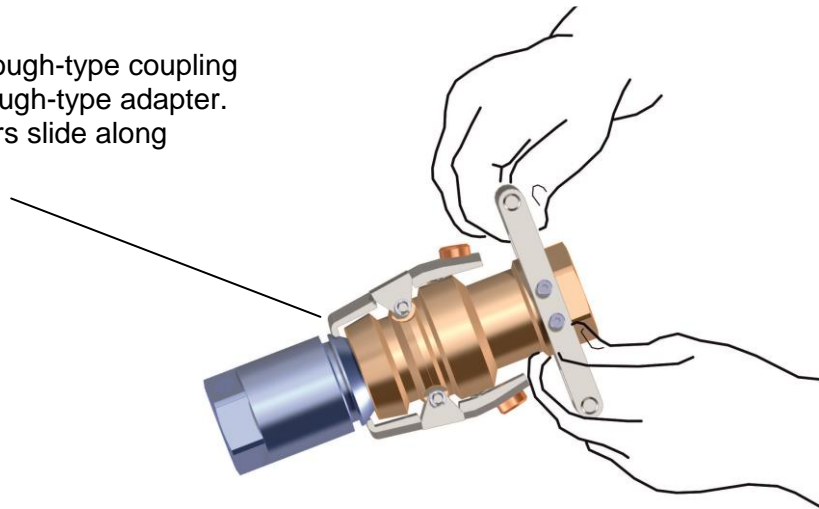

and engage in the groove.

The two coupling halves are now mechanically connected and the valves opened.

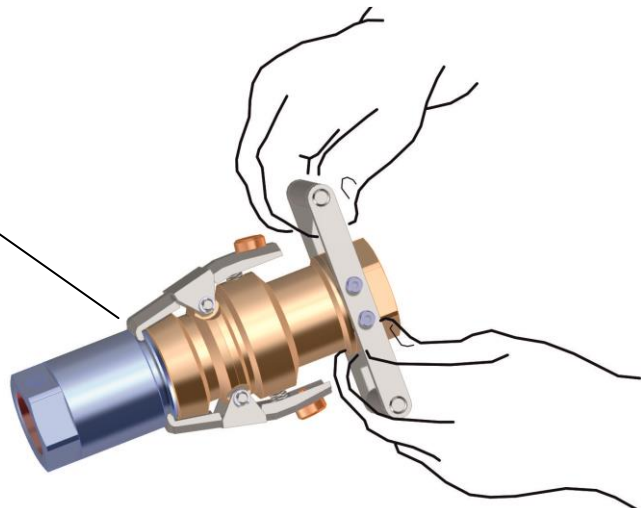

## Operating Instruction

### 8.2 Decoupling process

Hold the self-sealing coupling as shown in the figure here, and squeeze the levers.

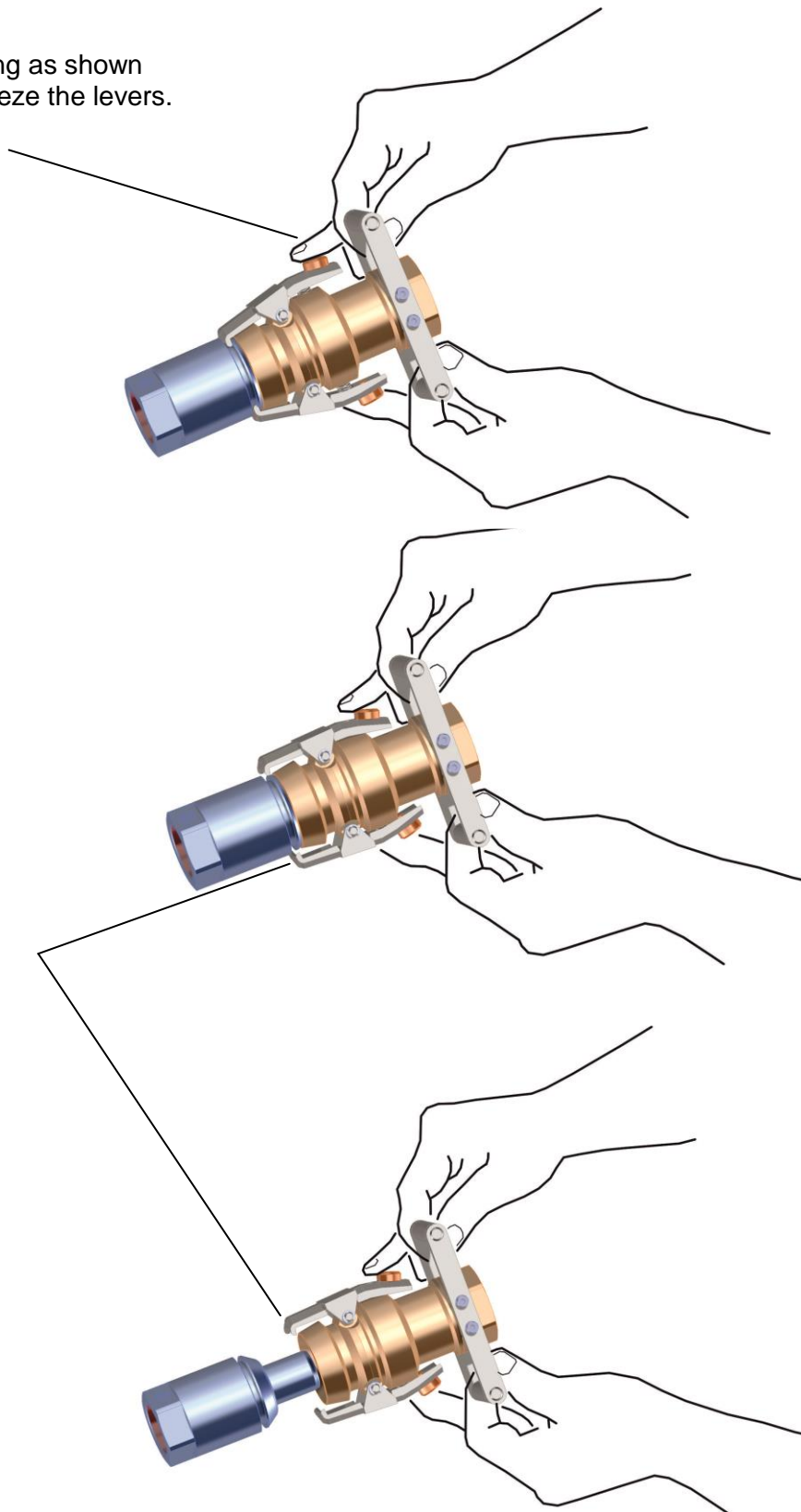

As soon as the levers are free of the adaptor, the coupling can be removed.

And the valves close automatically, if present.



## Maintenance and function test

---

### **9 Maintenance and function test**

The WALTHER – coupling units are to be handled in such a way exterior damage to the elements as well as to all moving parts is prevented.

In order to minimise activation forces and to extend the lifetime of the coupling unit, we recommend lightly lubricating the connecting surfaces if this is permitted (see lubrication instructions).

In order to always ensure the functionality of the coupling unit and thus the protection of the operator, maintenance and functional testing must be carried out independantly of the operating instructions and at a suitable interval.

#### **Note!**

**In the event of maintenance that is carried out by neither WALTHER-PRÄZISION nor by personnel trained by WALTHER-PRÄZISION, the warranty of WALTHER-PRÄZISION is voided. This does not apply when maintenance is carried out by personnel trained by WALTHER-PRÄZISION.**

#### **Note!**

**In the event of media that is hazardous to health a coupling unit returned to WALTHER-PRÄZISION must be sent in a fully cleaned state. No media hazardous to health may be released from the coupling unit during the dismantling process. The sending party (customer) is responsible for this.**

#### **9.1 Maintenance:**

- With the coupling unit in the decoupled state, carry out an external visual check for damages and contamination.
- Contamination in the functional area that can be accessed from the outside (seal region, activation elements) must be removed by wiping.

In the event of damaged, cracked or corroded parts, the coupling unit must be removed and sent to WALTHER-PRÄZISION for repair (see Note).

In the event of worn, brittle or overaged seals as well as serious contamination, it is the decision of the customer whether they wish to send the coupling unit WALTHER-PRÄZISION or whether they wish to repair it themselves (see Note).

## Maintenance and function test

---

### 9.2 Functional testing:

As described in the operating instructions, the coupling unit is coupled, pressure is applied and it is decoupled and this process is carried out multiple times.

In doing so, the following should be taken into consideration:

- Proper, easy functionality when coupling and decoupling.
- Sealing of the coupling unit in the coupled and decoupled state.

In the event of damaged, cracked or corroded parts, the coupling unit must be removed and sent to WALTHER-PRÄZISION for repair (see Note).

In the event of worn, brittle or overaged seals as well as serious contamination, it is the decision of the customer whether they wish to send the coupling unit to WALTHER-PRÄZISION or whether they wish to repair it themselves (see Note).

### **Note!**

**When repairing, a pressure and sealing test must always be carried out.  
This may also be completed by means of the working process.  
The procedure and scope of this test is described in the "Test" section.**

## Maintenance and function test

### 9.3 1-11-019-0-WR533-AAAI (HG)



**CAUTION**

When removing, the valve parts jump out forcefully out of the housing due to the pretensioned valve spring.

Bruises and crushes of parts of the body are possible

It must be counterbalanced by hand.

order of disassembly

2x fastening clip  
ident no 54158  
4-11-012-502-TE

4x safety washer  
ident no 29831  
DIN 6799 - 029831

1x o-ring  
ident no 81187  
7-045 - 081187

#### **Assembly :**

Assembly is to be carried out in reverse order.

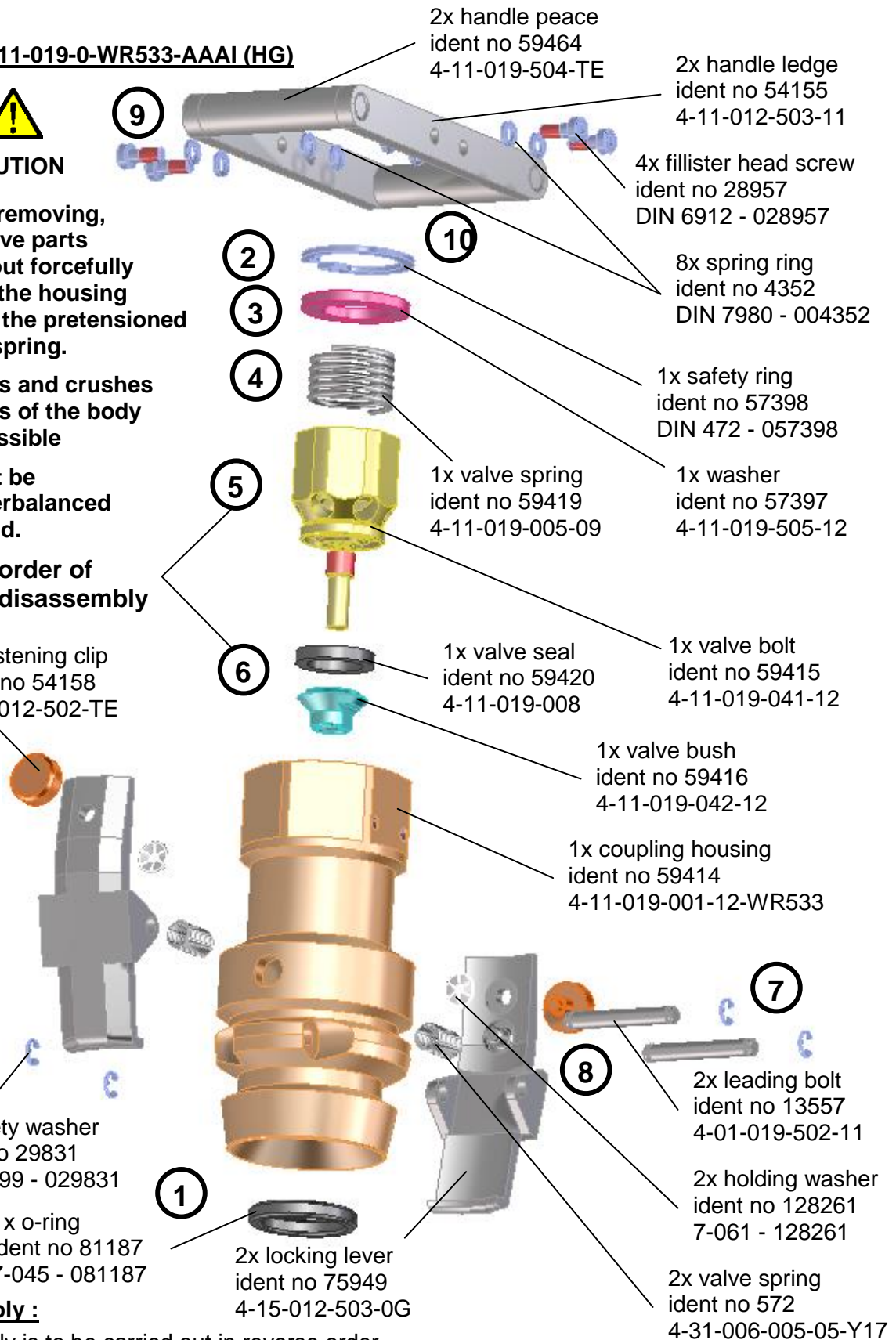

## Maintenance and function test

### 9.4 1-11-019-0-WR533-AAAH (HG)



**CAUTION**

When removing, the valve parts jump out forcefully out of the housing due to the pretensioned valve spring.

Bruises and crushes of parts of the body are possible

It must be counterbalanced by hand.

order of disassembly

2x fastening clip  
ident no 54158  
4-11-012-502-TE

4x safety washer  
ident no 29831  
DIN 6799 - 029831

1x o-ring  
ident no 66382  
7-045 - 066382

#### **Assembly :**

Assembly is to be carried out in reverse order.

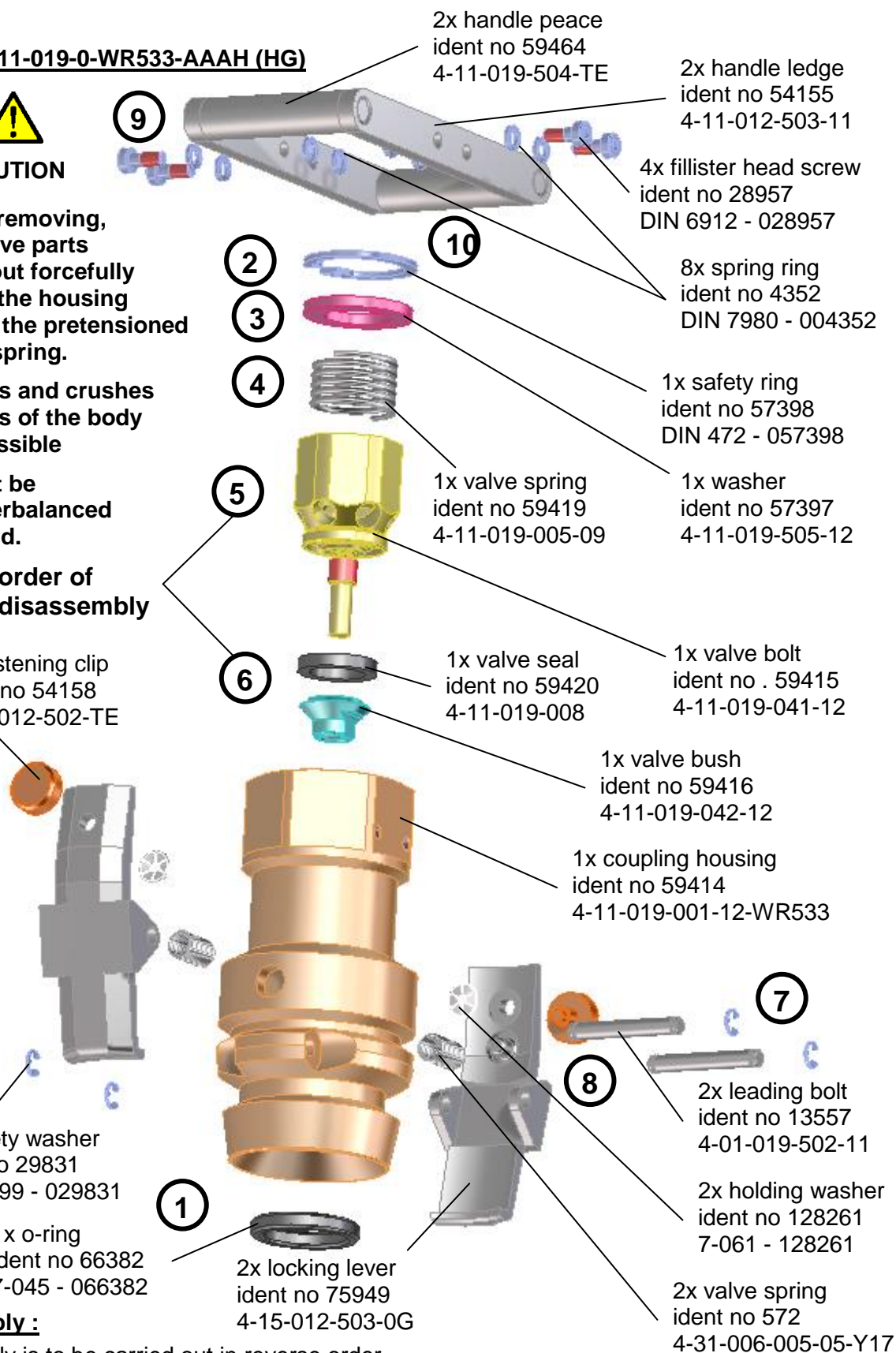

## Maintenance and function test

### 9.5 1-11-019-2-WR533-AAAA

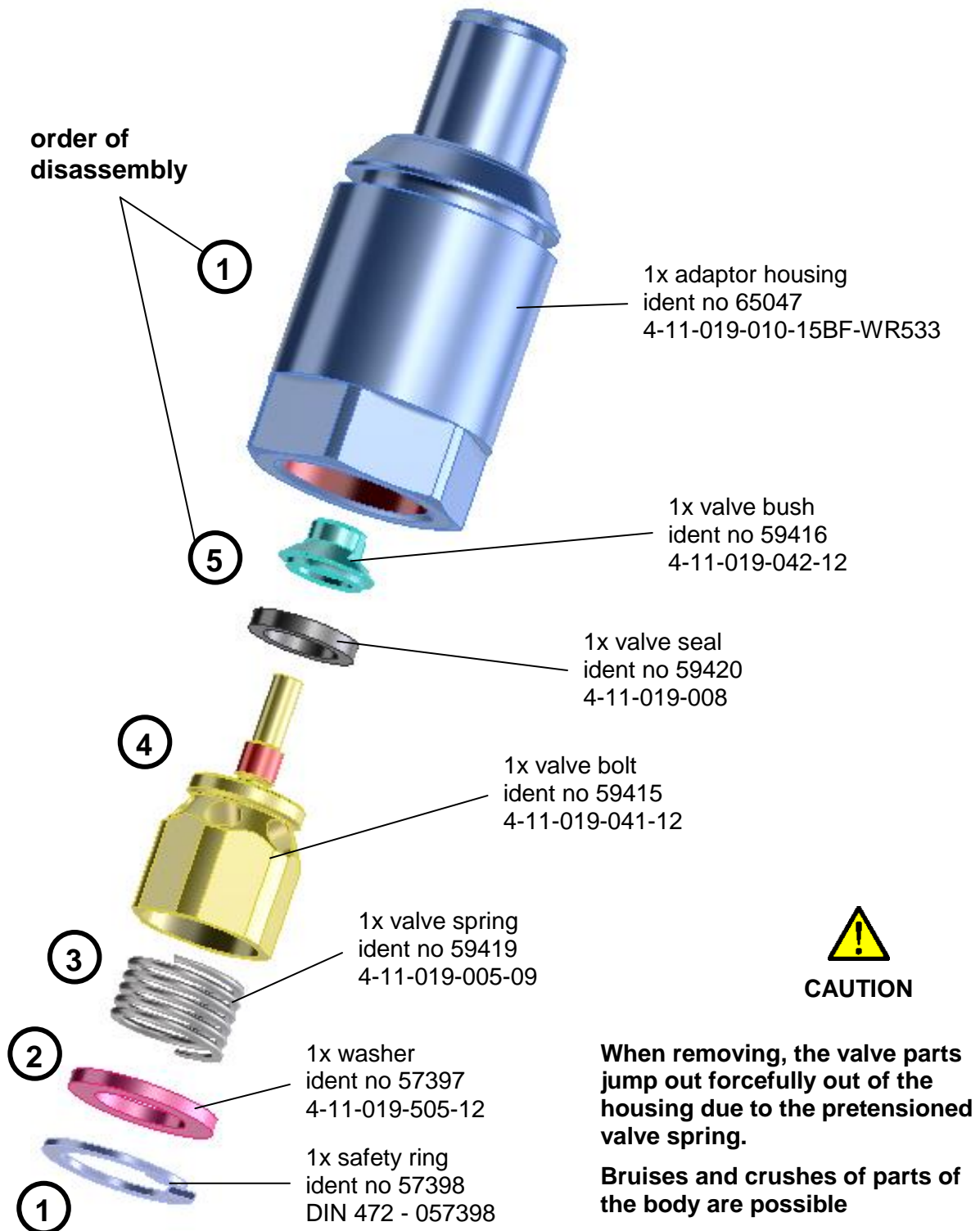

**CAUTION**

**When removing, the valve parts jump out forcefully out of the housing due to the pretensioned valve spring.**

**Bruises and crushes of parts of the body are possible**

**It must be counterbalanced by hand.**

**Assembly :**

Assembly is to be carried out in reverse order.

## 10 Test

For applications up to 2 bar, WALTHER-PRÄZISION recommends a leakage test by immersion trial. For applications above 2 bar, it is up to the user, if a leakage test by immersion trial or a pressure test by test bench has to take place.

### 10.1 Immersion test

#### 10.1.1 Test setup of the connected state (schematic view)

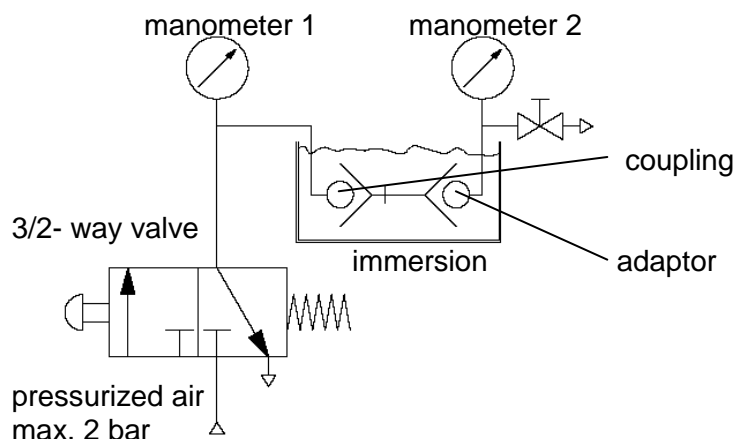

#### 10.1.2 Test procedure

- Prepare test setup
- 3/2-way valve is operated by sensing device and held up during the test.
- Valve is impinged with max. 2 bar pressurized air, both manometers show the same existing pressure.
- The holding time of the test is 10 seconds.
- To stop testing, release the sensing device at the 3/2-way valve. Through the preload, the 3/2-way valve runs back to the starting position.
- The medium in the test setup (pressurized air) escapes through the 3/2-way valve. Both manometers must show **0 bar** now.

### Attention

**If this does not happen, the test is not carried out correctly.  
It is not allowed to disconnect now.**

- By opening the stopcock at manometer 2, the remaining pressure can be reduced now.
- As soon as both manometers show 0 bar, disconnecting and dismantling of the test setup is permitted.
- After successful failure detection and elimination, the test has to be repeated correctly.
- After the test, the valve has to be dried as soon as possible in warm air (recommendation: 45 – 55 °C, approx. 30 min. in air stream, up to 2 hours in stagnant air, depending on the device).

### 10.1.3 Test disconnected

Test setup and procedure are identical for both coupling and adaptor.

### 10.1.4 Test setup of the disconnected state (schematic view)

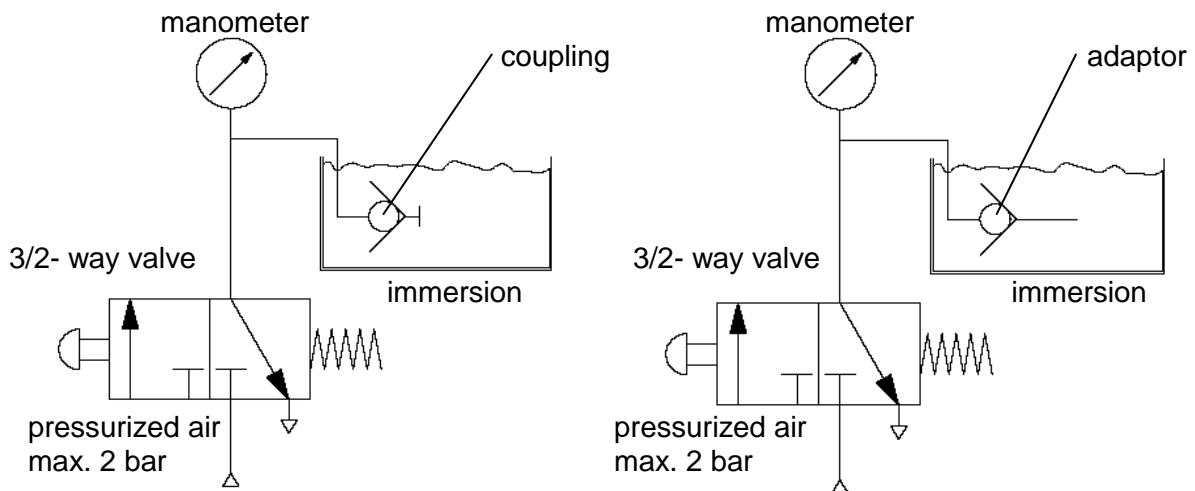

### 10.1.5 Test procedure

- Prepare test setup
- 3/2-way valve is operated by sensing device and held up during the test.
- Valve is impinged with max. 2 bar pressurized air, both manometers show the same existing pressure.
- The holding time of the test is 10 seconds.
- To stop testing, release the sensing device at the 3/2-way valve. Through the preload, the 3/2-way valve runs back to the starting position.
- The medium in the test setup (pressurized air) escapes through the 3/2-way valve. After correct test setup, the manometer will show **0 bar** again.
- Dismantling of the test setup is permitted now.
- After the test, the valve has to be dried as soon as possible in warm air (recommendation: 45 – 55 °C, approx. 30 min. in air stream, up to 2 hours in stagnant air, depending on the device).

### 10.1.6 Test result

During the holding time of 10 seconds, bubbling shall not occur neither in connected, nor in disconnected state. If bubbling occurs in these 10 seconds, the valve has to be considered leaking and is not permitted for use. Failure detection and elimination has to be carried out as well as a new test.

## 10.2 Pressure test

### 10.2.1 Test setup of connected state (schematic view)

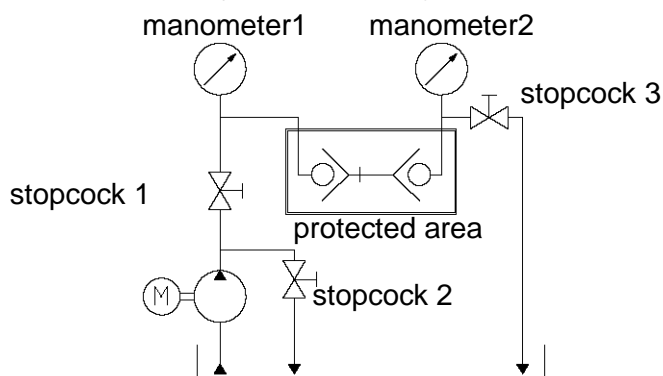

### 10.2.2 Test procedure

- Prepare test setup.
- The test setup must be laid out in accordance to relevant safety regulations, e. g. industrial safety regulations etc. and to the required pressure. The container (protected area) in which the valve is laid during the test, must be laid out so that neither escaping media under pressure nor parts of the test piece can endanger the operator (e. g. bursting).
- Test media is water or oil, according to the material of the valve which has to be tested. The sealing material EPDM shall not be tested with oil.
- The user of the test setup is required to plan and control the implementation of appropriate measures to ensure a safe operation.
- At the beginning of the test, stopcock 1 is open, stopcocks 2 and 3 are closed.
- Before the pressure test, it has to be ensured that no gaseous/compressed media is left in the valve.
- For this purpose, the valve has to be vented before pressurization. Open stopcocks 1 and 3 and lead the test media through the test piece until there is no more gaseous media left.
- Switch off pump and close stopcock 3.
- Slowly apply pressure to the valve. Pressure test is 1,3 x working pressure. (working pressure, please see product description).
- Both manometers show test pressure.
- Close stopcock 1; test pressure is locked within the valve for 5 min.
- Switch off pump and open stopcock 2.
- To finish testing, open stopcock 1 and the test media will flow back into the container.
- Both manometers must show **0 bar** now.

#### **Attention**

**If this is not happened, the test is not carried out correctly.**

**Disconnecting is not permitted now.**

- By opening stopcock 3, the residual pressure can escape.
- If both manometers show 0 bar, disconnecting and dismantling of the test setup is permitted.



- After successful failure detection and elimination, the test has to be repeated correctly.
- After the test, the valve has to be dried as soon as possible in warm air (recommendation: 45 – 55 °C, approx. 30 min. in air stream, up to 2 hours in stagnant air, depending on the device).

### 10.2.3 Test disconnected

Test setup and test procedure are identical for both coupling and adaptor.

### 10.2.4 Test setup of the disconnected state (schematic view)

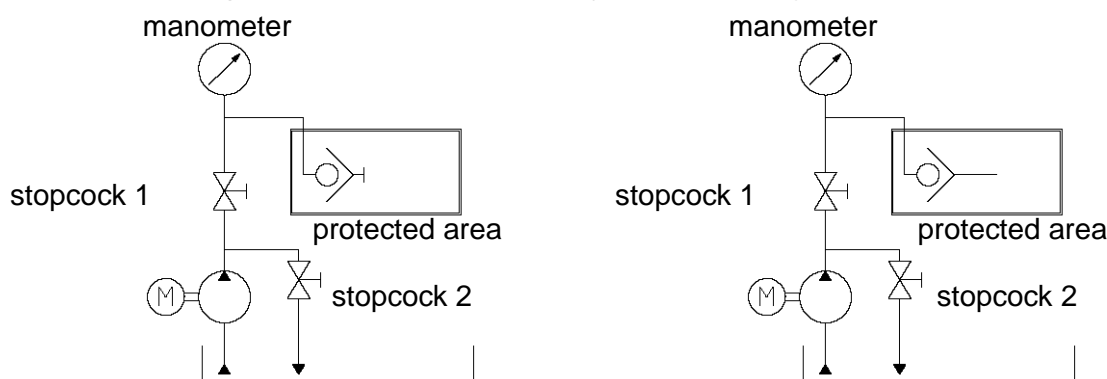

### 10.2.5 Test procedure

- Prepare test setup.
- The test setup must be laid out in accordance to relevant safety regulations, e. g. industrial safety regulations etc. and to the required pressure. The container (protected area) in which the valve is laid during the test, must be laid out so that neither escaping media under pressure nor parts of the test piece can endanger the operator (e. g. bursting).
- Test media is water or oil, according to the material of the valve which has to be tested. The sealing material EPDM shall not be tested with oil.
- The user of the test setup is required to plan and control the implementation of appropriate measures to ensure a safe operation.
- Before the pressure test, it has to be ensured that no gaseous/compressed media is left in the valve.
- For this purpose, the valve has to be vented before pressurization. This is only possible in coupled state. Open Stopcocks 1 and 3 (see test in coupled state) and lead test media through test piece until there is no more gaseous media left.
- Switch off the pump, disconnect the unit and slowly pressurize the respective side (coupling or adaptor). Test pressure is 1,3 x working pressure (working pressure see product description).
- Manometer shows test pressure.
- Close stopcock 1; test pressure is locked within the valve for 5 min.
- Switch off pump and open stopcock 2.

- To finish testing, open stopcock 1 and the test media will flow back into the container. The manometer must show **0 bar** after correct test setup.
- The test setup can be dismantled.
- After the test, the valve has to be dried as soon as possible in warm air (recommendation: 45 – 55 °C, approx. 30 min. in air stream, up to 2 hours in stagnant air, depending on the device).

#### 10.2.6 Test result

After 5 min. of testing, the pressure decrease must not exceed 5 % in connected and disconnected state with a test pressure up to 700 bar.

With a test pressure of more than 700 bar, the pressure decrease must not exceed 3 %. If the pressure loss is higher or if media escapes obviously, the valve is to be considered leaking and is not permitted for use.

Failure detection and elimination as well as a new test are required.

#### 10.3 Documentation

Tests have to be documented with registration of test pressure, test media, name/date and signature.

## **11 Storage**

The coupling must be stored in a way that it cannot be damaged.

To avoid damage or dirt the transportation covers must be attached on all connections.

The storage conditions of the coupling depend on the guidelines applicable to the gaskets, since improper storage can lead to deterioration of the gaskets.

The following points must be observed:

- The gaskets must be stored dry.
- For the preservation of the gaskets, the gaskets should not be stored where they are exposed to the effects of daylight.
- For protection against oxygen, the gaskets should be stored in the original packaging.

## **12 Shut-down**

At the end of the service life the coupling or its components have to be disposed non-polluting and according to the legal regulations.

For that the local public or private disposal societies should be taken.

## 13 Index

### A

Accident prevention regulations .....	14
adaptor .....	14
Assembly work .....	14

### C

Commissioning .....	5
Consumables .....	11
Consumer side .....	14
Contact .....	2
coupling .....	5, 12
Coupling .....	12, 27
Coupling connection .....	12
Coupling halves .....	12
Customer care, individual .....	2

### D

Damage compensation .....	5
Depressurized .....	14
Depressurized state .....	14
Disposal societies .....	27

### E

Environmental conditions .....	11
--------------------------------	----

### F

Fully cleaned state .....	17
Function test .....	14

### G

General .....	5
General terms and conditions for delivery and service .....	11
Guarantees, void without notification .....	11
Guidelines applicable to the gaskets .....	27

### I

Improving .....	5
Index .....	29

### L

Liability .....	5
Lifetime .....	17
Line network .....	14

### M

Maintenance .....	5, 17
Maintenance and function test .....	17
Media that is hazardous to health .....	17
Montage .....	19, 20, 21
Moving parts .....	14

### N

Network side .....	14
No liability .....	5

### O

Operated, not according to the intended purpose .....	11
Operated, with a disregard for the specifications .....	11
Operating instruction .....	1, 14
Operating instructions .....	14
Operating pressure .....	12
Operating pressures .....	12
Original parts .....	11

### P

Parts, damaged .....	17, 18
personnel trained by Walther-Präzision .....	17
Pipeline network .....	14
Purchase contract .....	11
Purposes .....	12

### R

Regulations .....	5
Responsibility .....	17

### S

Safe operation .....	12
Safety instructions .....	6
Scope of delivery, actual .....	5
Seal .....	17, 18
Sealing test .....	18
Self-sealing adaptor .....	14
Service and maintenance contract .....	2
Service claims, void without notification .....	11
Shut-down .....	27
Storage .....	27
Storage conditions .....	27

---

<i>T</i>		Uses.....	12
Technical values .....	12	<i>V</i>	
Third-party items.....	11	verantwortlich.....	12
Translation errors.....	5	Violation .....	12
Transportation covers .....	27	Visual check.....	17
<i>U</i>		<i>W</i>	
unpressurized .....	12	Warranty, void without notification .....	11
unpressurized state .....	12	Warranty .....	11
Use .....	14	Warranty, excluded from .....	11