

Operating instruction english

Revision	C
Date	14.05.2006
Issuer	NH

This operating instruction is not subject to the updating

Self sealing coupling DN 4

1-HG-004-9-SA514-....-Y07
1-HG-004-0-NP513-....-Y05



Vor Beginn aller Arbeiten
Betriebsanleitung lesen!

*Read operating instruction
before beginning of all works!*

Betriebsanleitung immer
AUFBEWAHREN!
griffbereit am Gerät

*Always KEEP operating
instruction! In a ready hand
way at the device*

Achtung: Vor Inbetriebnahme
Gerät auf mängelfreien Zustand
und technisch einwandfreie
Funktion kontrollieren.

*Caution: Before starting-up
check device on faultless
condition and technically
perfect function.*

Das Original ist die
deutsche Fassung

*The German version
is the original*

This coupling is a quality product, in which special attention has been paid to high functionality, ease of operation, safety and reliability. As an item of technical equipment this tool-changer is intended for use in the commercial, industrial area and for operators, who have been trained by specialists in the handling of technical systems / tools.

Customer care:

As part of our individual customer care we will be happy to assist you in questions relating to use and operation and on any problems encountered.

Service and maintenance:

In order to maintain the high technical performance capability and reliability of your docking system over many years, we recommend regular inspection and maintenance.

We can thereby offer you optimum support by our Customer Service department and the conclusion of a service and maintenance contract. Please ask for a quotation.

Carl Kurt Walther GmbH & Co. KG
PO Box 42 04 44
42781 Haan
Westfalenstraße 2

Tel.: +49 (0) 2129 567-0
Fax: +49 (0) 2129 567 450

E-Mail: info@walther-precision.de
Internet: www.walther-precision.de

Contact:

Application technology and service

Holger R. Figge
Telephone: (02129) 567-591
Telefax: (02129) 567-590
Handy: (0162) 2090100
e-mail: hfigge@walther-precision.de

Further addresses and telephone numbers of contacts can be found on the Internet on our homepage under www.walther-precision.de "Service / Customer service".

List of Contents

1	<u>List of Contents</u>	
1	LIST OF CONTENTS	3
2	GENERAL.....	4
3	WARRANTY.....	5
4	SAFETY INSTRUCTIONS.....	6
5	PRODUCT DESCRIPTION OF THE SELF SEALING COUPLING	7
5.1	INTENDED USE.....	7
5.2	TECHNICAL DATA.....	7
6	GENERAL ARRANGEMENT DRAWINGS / PARTS LISTS	9
7	INSTALLATION INSTRUCTION	14
8	OPERATING INSTRUCTION.....	15
8.1	CONNECTION PROCESS	16
8.2	DISCONNECTION PROCESS	17
9	MAINTENANCE INSTRUCTION	18
9.1	MAINTENANCE AND FUNCTIONAL TEST	18
9.1.1	<i>Maintenance includes following items:</i>	<i>18</i>
9.1.2	<i>Functional test includes following items:.....</i>	<i>18</i>
10	STORAGE.....	19
11	SHUT-DOWN	20
12	ORDER NUMBER CODE.....	21
13	INDEX	22

2 General

This manual contains all regulations for operation, commissioning and maintenance of the locking coupling element coupling HG-004.

All information and notes in this operating manual were collated while taking into consideration the valid regulations, the current engineering related status of development as well as our many years of experience and acquired knowledge.

Translations of this operating manual were also produced according to the best of knowledge. However, we cannot assume liability for any translation errors. The German version provided for this operating manual is considered the authoritative version.

The actual scope of delivery can deviate from the explanations and graphic representations described herein under certain circumstances, e.g. in the case of special designs, utilization of additional order options or because of state-of-the-art technical alterations. If you have any questions, please contact the manufacturer.



This operating manual must be read carefully before starting work on or with the equipment, in particular before commissioning!

The manufacturer assumes no liability for damage or faults arising from non-compliance with the instructions in this operating manual.

The operating manual must be kept directly with the equipment and be accessible to all persons who work on or with the equipment.

It is not permitted for the operating manual to be passed to third parties and if applicable this will incur damage compensation.

All other rights reserved.

Before commissioning the device must be checked for being not defective and its technically perfect function.

The German version is the original.

We reserve the right to make technical alterations to the product within the context of improving the usage properties and further development.

The operating manual remains our property.

Any reproduction, use by or communication to third parties incurs a penalty and will be pursued by court action (copyright law against unfair competition, BGB [German Civil Code]).

All rights reserved in the case of a patent award (Paragraph 7, Section. 1 of the patent law - PG) or entry as a patented design (Paragraph 5, Section 4 of the patented design law - GMG).

3 Warranty

The warranty conforms to:

the “General Conditions for Delivery and Capacity” of C.K. Walther GmbH & Co. KG of the state which was valid at the date of the purchase contract

the regulations agreed in the purchase contract and.

Wearing parts are generally excluded from the warranty.

Typical wearing parts of products from company C.K. Walther GmbH & Co. KG are for example:

- seals
- springs

Safety instructions

4 Safety instructions

Using these couplings does not release the customer from his obligation to comply with the pertinent work safety regulations e.g. operational safety regulations, etc. The duty to take due care by the operator of the couplings includes planning measures to ensure proper operation and monitoring their implementation.

Hazard notes

If the wrong product has been selected or if there is improper use or maintenance has been omitted, then hazards arise and personal injuries and material damage can occur from:

- hazardous emission of fluid or individual particles/coupling parts.
- function impairments of connected systems or tools.

The operator must in particular make sure that

- the couplings are only used according to the intended purpose.
- the couplings are only operated in a perfect, functioning condition.
-  - the operating manual is always in a legible condition and is available in its entirety to operating personnel.
- the operating personnel are sufficiently acquainted with the working method and the safety notes for the coupling.
- no safety devices must be removed and/or deactivated during operation of the couplings.
- before installing or dismantling the couplings, you have made sure that the couplings have not been pressurized.
- icings must be avoided as these may result in functional impairment, especially with regard to the automatic lock.

After completing assembly and installation work and before commissioning the coupling, the following items have to be observed:

Check once again that all screw connections are securely fitted.

Before commissioning the couplings, a function test must be carried out (see maintenance and function test).

Product description of the self sealing coupling

5 Product description of the self sealing coupling

Coupling connection consists of:

- self sealing coupling 1-HG-004-0-NP513-....-Y05
- thru-type adaptor with check valve 1-HG-004-9-SA514-....-Y07

5.1 Intended use

- Coupling is only used as connection of two lines.
- The connection/disconnection of the coupling may be only made in unpressurized state of the self sealing coupling.
The refuelling receptacle can be pressurized between 0 and 875 bar during connection and disconnection process.
- The connection and disconnection process is carried out by hand; the connection process is boosted by an automatic lock;
i.e. after disconnection the locking sleeve is always in the position ready to be locked and locks automatically after insertion of the refuelling receptacle into the coupling.
The locking sleeve must not be pulled back by hand for connection.
Please observe the corresponding operating and safety instructions.
- If the pressure is higher than 5 bar, disconnection is prevented by an axial safety locking device.
- Coupling is especially suitable for the following media/applications:
 - **gaseous hydrogen**
- For all other possible applications, Walther-Präzision should be consulted.

5.2 Technical data

- Working pressures of coupling depend on materials of individual parts.
- When determining the working with standardized threaded connections, the highest permissible working pressure of the connection must be taken into account.
- When selecting a suitable connection the following static pressure is possible:

<u>Working pressure (static)</u>	9-AAAL-Y07 and 0-AAAF-Y05:
	connected: 875 bar
	disconnected: adaptor side = 875 bar
	coupling side = 875 bar



Working temperature: -40°C bis +85°C

Cv flow coefficient: self sealing coupling -> thru type adaptor
(both sides self sealing) = 0.29

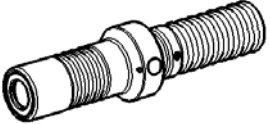

Product description of the self sealing coupling

- The coupling is not determined for any types of use and technical values other than those listed here.
- Safe operation is not guaranteed if the coupling is used contrary to its intended use and technical values
- The operator of the coupling is responsible for all personal injuries or material damage that occur from non-intended use and disregard of the technical values; the manufacturer assumes no responsibility in these cases.

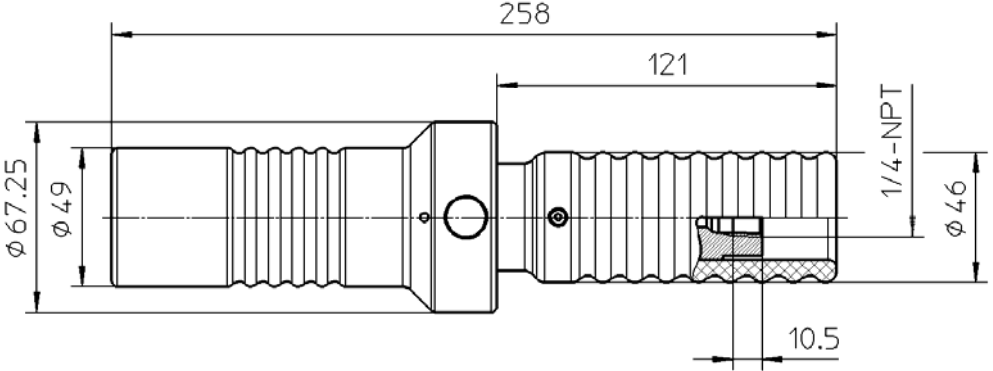
General arrangement drawings Parts Lists

	Verschlußkupplung DN4 self sealing coupling n.b. 4	
		
		
C.K. Walther Bestell-Nr.: 1 - HG - 004 - 0 - NP513 - AAAF - Y05 C.K. Walther part-no.:		
Werkstoffe: 1.4404 / 1.4571 <i>materials: AISI 316L / AISI 316Ti</i>		
Dichtungen: Wasserstoff beständig <i>seals: suitable for hydrogen</i>		
zu Kuppeln mit: Betankungsrippel 1-HG-004-9-.....-.....-Y.. <i>mateable with: receptacle 1-HG-004-9-.....-.....-Y..</i>		
max. Betriebsdruck ohne Berücksichtigung der Anschlüsse: 875 bar <i>max. working pressure without consideration of end connection: 12.700 psi</i>		
Projekt / Anschlußspezifischer Betriebsdruck: ... bar <i>project / end connection specific working pressure: psi</i>		
Hinweis: ... <i>remark: ...</i>		
		K-D-GB
Ausführung: B		Datum
vom: 2006/03/28 AKam		Ersterst. 2004/07/15 AKam
A 100554		Gezeichnet 2004/07/15 AKam
		Geprüft 2004/07/16 RKo
		A.-geprüft 2006/03/28 RKo
Die Zeichnung ist unser Eigentum. Jede Vervielfältigung, Verwertung oder Mitteilung an dritte Personen ist strafbar und wird gerichtlich verfolgt (Urheberrechtsgesetz, Gesetz gegen unlauteren Wettbewerb, BGB). Alle Rechte für den Fall der Patenterteilung (§7 Abs.1PG) oder GM-Eintragung (§5 Abs.4 GMG) vorbehalten.		

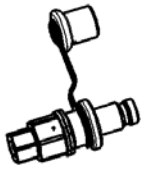
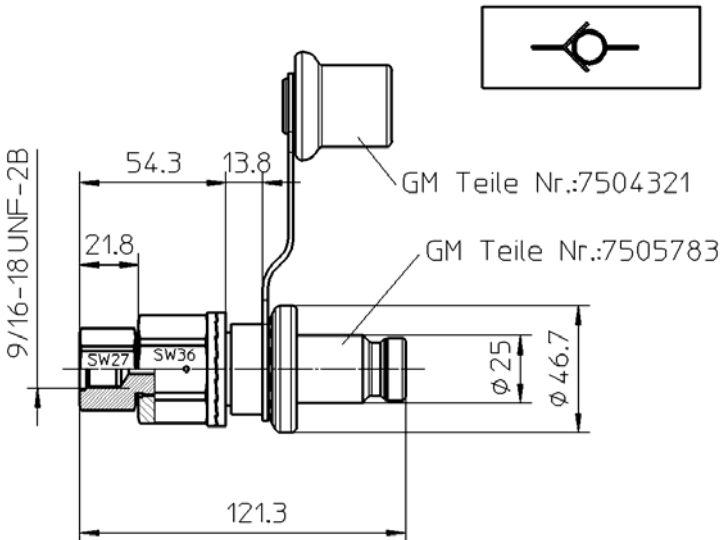
General arrangement drawings Parts Lists

	<h3>Betankungsrippel DN4</h3> <p>receptacle n.b.4</p>																		
	 <p>GM Teile Nr.:7504321 GM Teile Nr.:7505783</p> <p>SW27 SW36</p> <p>9/16-18 UNF-2B</p> <p>54.3 13.8 21.8 121.3</p> <p>Ø 25 Ø 46.7</p>																		
<p>C.K. Walther Bestell-Nr.: 1 HG 004 9 SA514 AAAL Y07</p> <p>C.K. Walther part-no.:</p>																			
<p>Werkstoffe: 1.4404 / 1.4571 / POM materials: AISI 316L / AISI 316Ti / POM</p> <p>Dichtungen: Wasserstoff beständig seals: suitable for hydrogen</p> <p>zu Kuppeln mit: Verschlusskupplungselement 1-HG-004-0-.....-Y05 mateable with: Self sealing coupling element 1-HG-004-0-.....-Y05</p> <p>max. Betriebsdruck ohne Berücksichtigung der Anschlüsse: 875 bar max. working pressure without consideration of end connection: 12.700 psi</p> <p>Betriebstemperatur: -40°C bis +85°C working temperature: -40°C bis +85°C</p> <p>Hinweis: ... remark: ...</p>																			
<div style="border: 1px solid black; padding: 2px; display: inline-block;">K-D-GB</div>																			
Die Zeichnung ist unser Eigentum. Jede Vervielfältigung, Verwertung oder Mitteilung an dritte Personen ist strafbar und wird gerichtlich verfolgt (Urheberrechtsgesetz, Gesetz gegen unlauteren Wettbewerb, BGB). Alle Rechte für den Fall der Patenterteilung (§7 Abs.1PG) oder GM-Eintragung (§5 Abs.4 GMG) vorbehalten.		<table border="1" style="width: 100%; border-collapse: collapse;"> <tr> <td style="width: 30%;">Ausführung: B</td> <td style="width: 10%;"></td> <td style="width: 15%;">Datum</td> <td style="width: 45%;">Name</td> </tr> <tr> <td rowspan="4" style="vertical-align: top;">vom: 2006/02/20 AKam</td> <td>Ersterst.</td> <td>2006/01/27</td> <td>AKam</td> </tr> <tr> <td>Gezeichnet.</td> <td>2006/01/27</td> <td>AKam</td> </tr> <tr> <td>Geprüft</td> <td>2006/01/30</td> <td>AHei</td> </tr> <tr> <td>A.-geprüft</td> <td>2006/02/21</td> <td>NH</td> </tr> </table>	Ausführung: B		Datum	Name	vom: 2006/02/20 AKam	Ersterst.	2006/01/27	AKam	Gezeichnet.	2006/01/27	AKam	Geprüft	2006/01/30	AHei	A.-geprüft	2006/02/21	NH
Ausführung: B		Datum	Name																
vom: 2006/02/20 AKam	Ersterst.	2006/01/27	AKam																
	Gezeichnet.	2006/01/27	AKam																
	Geprüft	2006/01/30	AHei																
	A.-geprüft	2006/02/21	NH																

General arrangement drawings Parts Lists

Pos. pos.	Benennung description	Zeichnungsnummer / Abmessung drawing no. / dimension	Stck. pcs.	Werkstoff / Ident-Nr. material / ID-no.	Bemerkung remarks
01	Kupplungsgehäuse coupling housing	4-HG-004-001-...-Y02	1		
02	Verriegelungshülse locking sleeve	4-HG-004-002-...-Y02	1		
03	Verschlußstück end connection	4-HG-004-003-...-NP513-Y05	1		
04	Verriegelungsfeder locking spring	4-HG-004-006-01-Y02	1		
05	Ventilbalzen valve ball	4-HG-004-041-...-Y02	1		
06	Ventilbüchse valve bush	4-HG-004-042	1		
07	Schutzhülse protection sleeve	4-HG-004-501-...-Y05	1		
08	Griffhülse grip sleeve	4-HG-004-502-...-Y05	1		
09	Ventilsatz valve insert	4-HG-004-503-...-Y02	1		
10	Fanghülse capture sleeve	4-HG-004-504-...-Y02	1		
11	Feder spring	4-HG-004-506-01-Y02	1		
12	Ventildichtung valve seal	4-HG-004-507	1		
13	Mündungsschutz muzzle protection	4-HG-004-508-...-Y02	1		
14	Hülseinsatz sleeve insert	4-HG-004-509-...-Y05	1		
15	Rückstellfeder pull-back spring	4-HG-004-510-01-Y05	1		
16	Rückstellknopf pull-back button	4-HG-004-511-...-Y05	1		
17	Rückstellstift pull-back pin	4-HG-004-512-...-Y05	1		
18	Einsatz insert	4-HG-004-517-...-Y05	1		
19	Sperkolben block up piston	4-HG-004-520-...-Y05	1		
20	Wiederlage button	4-HG-004-515-...-Y05	1		
21	Verriegelungsglied locking link	4-CG-006-508-...-Y02	3		
22	Ventilfeder valve spring	4-LP-007-005-01	1		
23	Dichtung seal	4-HG-004-518-...-Y05	1		

Die Zeichnung ist unser Eigentum. Jede Vervielfältigung, Verwertung oder Mitteilung an dritte Personen ist strafbar und wird gerichtlich verfolgt (Urheberrechtsgesetz, Gesetz gegen unlauteren Wettbewerb, BGB). Alle Rechte für den Fall der Patenterteilung (§ 7 Abs. 1 PatG) oder GM-Eintragung (§ 5 Abs. 4 GMG) vorbehalten.

This drawing is our property. Any duplication, utilization or information to third-parties is punishable and will be legally pursued (Copyright law, law PG against unfair competition, BGB). All rights reserved in case of patent issuing (article 7, paragraph 1 PG) or GM registration (article 5, paragraph 4 GMG).

Blatt 1 von 2 Blatt Ersatz für: CAD-Stückliste nicht manuell ändern!
page of 2 page replacement for: Do not modify this CAD parts list manually!

Pos. pos.	Benennung description	Zeichnungsnummer / Abmessung drawing no. / dimension	Stck. pcs.	Werkstoff / Ident-Nr. material / ID-no.	Bemerkung remarks
24	Zylinderschraube flaster head screw	DIN 7984-M3 x 10	3		
25	O-Ring o-ring	2.9 x 1.78	1		
26	Stützring anti effusion ring	3.3+0.1 x 6+0.05 x 1.24	1		
27	Zylinderstift parallel pin	DIN 7-4m6 x 8	1		
28	Sicherungsring safety ring	DIN 472-15 x 1	1		
29	Spannstift dowel pin	DIN 1481-1.5 x 12	1		
30	Dichtung seal	4-HG-004-519-...-Y05	1		

Die Zeichnung ist unser Eigentum. Jede Vervielfältigung, Verwertung oder Mitteilung an dritte Personen ist strafbar und wird gerichtlich verfolgt (Urheberrechtsgesetz, Gesetz gegen unlauteren Wettbewerb, BGB). Alle Rechte für den Fall der Patenterteilung (§ 7 Abs. 1 PatG) oder GM-Eintragung (§ 5 Abs. 4 GMG) vorbehalten.

This drawing is our property. Any duplication, utilization or information to third-parties is punishable and will be legally pursued (Copyright law, law PG against unfair competition, BGB). All rights reserved in case of patent issuing (article 7, paragraph 1 PG) or GM registration (article 5, paragraph 4 GMG).

Blatt 2 von 2 Blatt Ersatz für: CAD-Stückliste nicht manuell ändern!
page of 2 page replacement for: Do not modify this CAD parts list manually!

General arrangement drawings Parts Lists

	Pos.	Benennung	Zeichnungsnummer / Abmessung	Stck.	Werkstoff/ Ident-Nr.	Bemerkung
 walther präzision	70	Betankungsrippel mit Rückschlagventil	1-HG-004-9-00000-AAAJ-Y07	1	Unterstückliste	
	71	Verschlußstück	4-HG-004-203-...-SA514-Y07	1	1.4404	*
	72	Drosselscheibe (NW5.5)	4-HG-004-504-...-00001-Y07	1	1.4404	
	73					
	74					
Übersichtszeichnung 1-HG-004-9-00000-...-Y07 verwendet!						
* Zugfestigkeit min. 600 N/mm ² Streckgrenze min. 325 N/mm ²						
<small>Die Zeichnung ist unser Eigentum. Jede Vervielfältigung, Verwertung oder Mitteilung an dritte Personen ist strafbar und wird gerichtlich verfolgt (Urheberrechtsgesetz, Gesetz gegen unlauteren Wettbewerb, BGB). Alle Rechte für den Fall der Patenterteilung (§ 7 Abs. 1 PatG) oder GM-Eintragung (§ 5 Abs. 4 GMG) vorbehalten.</small>						
Blatt von Blatt			Ersatz für: .		CAD-Stückliste nicht manuell ändern!	

DIN A 4

**walther
präzision**

Ausf.: B vom 23.11.2005 AKG

A 10841

Ersterrl. 21.11.2005	Datum	Name
Geschr. 21.11.2005	AKG	
Geprüft/ 21.11.2005	AKG	
	RKO	

Bestellnummer:
1-HG-004-9-SA514-AAAL-Y07

Betankungsrippel mit
 Rückschlagventil
 ohne Filter

Installation instruction

7 Installation Instruction

Subject to the general accident prevention regulations coupling is to be installed into a network in such a way that

- a satisfactory operation is guaranteed according to the operating instruction .
- the self sealing coupling is primarily used at the supply side and the refuelling receptacle primarily at the consumer side.
- external damage of the unit as well as all moving parts are excluded.

It has to be made sure that the network is sufficiently rinsed/blown and/or cleaned prior to installation of the self sealing coupling and the refuelling receptacle at the network.

The parts are to be protected against contamination and damage.



After the assembly works are finished a functional test is to be carried out with both, without pressure and under working pressure of the media elements according to operating instruction.

Operating instruction

8 Operating Instruction

In order to avoid critical injuries of the staff and damage at the self sealing coupling during operation, coupling may be only used for the stated applications.

During the connection and disconnection process, the arising side forces may not be too high: this means that not only the self sealing coupling but also the first area of the hose behind the self sealing coupling must be axially aligned to the fuel adaptor. (stiff hose ! Bending radius not smaller than 1 m).

Operating instructions for the safe handling of the refuelling nozzle type HG

1. The connection process is to be carried out speedy until stop.
2. The correct lock of the fitting can be seen from the position of the locking sleeve. In the disconnected state the locking sleeve is behind and the front part of the coupling housing is visible. In the connected state the locking sleeve shoots up and covers the coupling housing completely.
3. An additional safety feature is the "pressure active unlocking safety device" (white button) which is signalized by driving out of the white button. This takes place automatically from a working pressure of approx. 5 bar. This represents a secure sign for the proper lock, too. Only after this activation the working pressure is to be increased.
4. Of course, we do not want to intervene the refuelling process, however, we assume that the leakage tests are carried out at small pressures < 40 bar. In this case there is no safety risk even in the case of conscious maloperation and/or blockade. The coupling valve closes and the refuelling process cannot take place.

Operating instruction

8.1 Connection process

Before every coupling process, a visual inspection of the self sealing coupling and the adaptor must be made. In case of damage or deformations which can possibly cause a disturbance of operating, the fitting has to be returned to the manufacturers factory.

For connection, the unpressurized self sealing coupling is taken and held at the rear grip sleeve (hose area).

Then the self sealing coupling is axially plugged onto the fuel adaptor and fully inserted.

In doing so, the automatic lock is activated and the coupling locks automatically.

Parallel to the insertion of the self sealing coupling onto the refuelling receptacle the valve opens on the coupling side.

After the connection is pressurized now with medium and pressure, the check valve is opened on the refuelling receptacle side through the applied pressure. Thus the medium flow is released.

Starting from a pressure of 5 bar, the axial safety locking device becomes active.

In doing so, the button of the axial safety locking devices protrudes from the outside of the self sealing coupling. (see fig. 1)



Fig. 1

Operating instruction

8.2 Disconnection process

Before disconnection, the connection must be depressurized.

In doing so, the check valve at the thru-type adaptor's side closes and shuts off the tank.

The process of de-pressurization of the connection deactivates the axial safety locking device and the button returns into the contour of the self sealing coupling. (see fig. 2).



Fig. 2

The unpressurized self sealing coupling is taken and held with one hand at the rear grip sleeve (hose area).

Using the second hand, the locking sleeve is pulled along the front protective sleeve to the rear in direction of the hose and the self sealing coupling is pulled from the fuel adaptor.

When pulling the self sealing coupling from the fuel adaptor, the valve in the coupling closes automatically.

9 Maintenance Instruction

Preventive maintenance measures

WALTHER self sealing couplings are to be operated in such a manner that external damages to elements and all moving parts are avoided.

9.1 Maintenance and functional test

In order to always guarantee function of the self sealing coupling and hence safety of operator, a maintenance and functional testing must be made in appropriate periods of time depending on operating conditions.

self sealing coupling in each case after **->15000 fuellings**
alternatively the maintenance is to be carried out **three** years after initial operation.

refuelling receptacle with check valve in each case after **->15000 fuellings**
alternatively the maintenance is to be carried out **ten** years after initial operation.

The coupling unit leaves the factory without being greased or oiled. Therefore, **no** grease or preservatives should be used for the coupling within the framework of maintenance work.

9.1.1 Maintenance includes following items:

- A visual inspection of self sealing coupling and self sealing adaptor regarding damage and contamination has to be made.
- Dirt at the functional area (sealing area, operating elements) which is easily accessible from outside should be removed by simply wiping-off.

If there are damaged, torn or corroded parts or in case of worn, embrittled or overaged seals as well as strong pollutions the repair has to take place at the manufacturer and/or service of the manufacturer.

9.1.2 Functional test includes following items:

As described in the operating instruction, coupling is several times connected, pressurized and then disconnected.

In doing so, the following has to be observed:

- Connection and disconnection process must be absolutely smooth.
- Coupling must be absolutely leak-proof in connected and disconnected state.

If there are damaged, torn or corroded parts or in case of worn, embrittled or overaged seals as well as strong pollutions the repair has to take place at the manufacturer and/or service of the manufacturer.

10 Storage

The couplings must be stored in such a way that no damages can occur at the couplings.

The storage conditions of the couplings must comply with the guidelines for the seals as these can change in properties due to improper storage.

The following items must be kept:

- The couplings must be stored dry.
- To safely conserve the seals and that means also the couplings they should not be stored under the effect of daylight.
- For protection against oxygen the seals and also the couplings shall be stored into the packing.

11 Shut-down

At the end of the service life the coupling or its components have to be disposed non-polluting and according to the legal regulations.

For that the local public or private disposal societies should be taken.

12 Order number code

1. 2. 3. 4. 5. 6. 7. 8. 9.
 X - XX - XXX - X - XXXXX - XX - X - XXX - XX
 X - XX - XXX - X - XXXXX - XXXXX - XXX - XX

1. Subject group
2. Series
Series description consists of either two letters or two digits.
3. Nominal size / nominal width
It is rounded up or rounded down to full units.
The indication can be numerical or alphanumeric.
4. Type of product and design
5. Type of connection
6. Material:
xx-x and xxxx possible
7. Material (seal version):
xx-x and xxxx possible
8. Y- or Z-design
9. Optional features

13 Index

<i>A</i>	
According to intended purpose.....	6
Acquired knowledge.....	4
adaptor side	7
Alterations	4
Assembly	6
<i>C</i>	
Commissioning.....	4, 6
connected.....	6, 7, 18
connection	7, 21
Connection process	16
Corroded.....	18
coupling.....	4, 6
Coupling.....	8, 20
coupling side	7
Couplings	6
Customer care.....	2
Cv flow coefficient.....	7
<i>D</i>	
Damage.....	4, 6
Damage compensation	4
Damaged.....	18
daylight.....	19
disconnected	7, 18
Disconnection process	17
Dismantling	6
Disposal societies	20
Disregard	8
dry.....	19
<i>E</i>	
Equipment	4
Experience.....	4
external damage.....	14
<i>F</i>	
Faults	4
Fluid	6
Function.....	6
Function test	6
Functionality.....	2
<i>G</i>	
General	4
General Arrangement Drawings.....	9
guarantee	18
<i>H</i>	
Hazard notes.....	6
Hazardous emission	6
<i>I</i>	
Implementation	6
Improvement	4
Index.....	22
Inspection	2
Installation Instruction	14
Intended use	7
<i>L</i>	
Legible condition	6
Liability.....	4
List of Contents	3
<i>M</i>	
Maintenance	2, 4, 6
Maintenance Instruction.....	18
Manual	4
<i>O</i>	
Operating instruction.....	1
Operating Instruction	15
Operation.....	2
Operational safety regulations.....	6
operator	6
Operators.....	2
original	4
<i>P</i>	
packing	19
Parts Lists.....	9
Perfect, functioning condition.....	6
Performance capability.....	2
Pressurized	6
Product description	7
Property	4
<i>Q</i>	
questions.....	4
<i>R</i>	
regulations.....	14
Regulations.....	4
Reliability.....	2
Repair work.....	18

responsible.....	8
<i>S</i>	
safe handling	15
Safety.....	2
Safety devices.....	6
Safety instructions	6
Scope of delivery	4
Screw connections.....	6
self sealing adaptor.....	7, 18
self sealing coupling.....	7, 15, 18
Self sealing coupling	1
Service.....	2
Shut-down	20
Special designs	4
Specialists.....	2
Status of development	4
steel.....	7
Storage.....	19
Systems.....	2, 6

<i>T</i>	
Technical data	7
Technical equipment	2
Technical values.....	8
Tools	2, 6
Torn.....	18
Translation errors	4
Types of use	8
<i>U</i>	
Use	2
<i>V</i>	
Version	4
<i>W</i>	
warranty	5
Work safety regulations	6
Working method	6
working pressure	7
Working pressure	7
Wrong product selection	6