

Operating manual English

Revision	A
Date	07.07.2011
Created by	PPI / NH

This operating manual is not subject to the updating

Clean-Break Safety Coupling

1-BF-025-0-.....-...-(Z..)

1-BF-025-2-.....-...-(Z..)

Vor Beginn aller Arbeiten Betriebsanleitung lesen!

Read operating instruction before beginning of all works!

Betriebsanleitung immer AUFBEWAHREN! griffbereit am Gerät

Always KEEP operating instruction! In a ready hand way at the device

Achtung: Vor Inbetriebnahme Gerät auf mängelfreien Zustand und technisch einwandfreie Funktion kontrollieren.

Caution: Before starting-up check device on faultless condition and technically perfect function.

Das Original ist die deutsche Fassung

The German version is the original



optional feature:

EX

This coupling is a quality product, in which special attention has been paid to high functionality, ease of operation, safety and reliability. As an item of technical equipment this coupling is intended for use in the commercial, industrial area and for operators, who have been trained by specialists in the handling of technical systems / tools.

Customer care:

As part of our individual customer care we will be happy to assist you in questions relating to use and operation and on any problems encountered.

Service and maintenance:

In order to maintain the high technical performance capability and reliability of your coupling over many years, we recommend regular inspection and maintenance.

We can thereby offer you optimum support by our Customer Service department and the conclusion of a service and maintenance contract. Please ask for a quotation.

Carl Kurt Walther GmbH & Co. KG
PO Box 42 04 44
42781 Haan
Westfalenstraße 2

Tel.: +49 (0) 2129 567-0
Fax: +49 (0) 2129 567 450

E-Mail: info@walther-precision.de
Internet: www.walther-precision.de

Contact:

Application technology and service

Holger R. Figge
Telephone: (02129) 567-591
Telefax: (02129) 567-590
Handy: (0162) 2090100
e-mail: hfigge@walther-precision.de

Further addresses and telephone numbers of contacts can be found on the Internet on our homepage under www.walther-precision.de "Service / Customer service".

Table of Contents

1 Table of Contents

1	TABLE OF CONTENTS	3
2	GENERAL	4
3	SAFETY INSTRUCTIONS	5
4	WARRANTY	6
5	PRODUCT DESCRIPTION OF SELF SEALING COUPLING	7
5.1	INTENDED USE.....	7
5.2	TECHNICAL DATA.....	7
5.3	OPTIONAL FEATURES.....	8
5.4	EXTENDED PRODUCT DESCRIPTION FOR APPLICATION ACC. TO ATEX-GUIDE LINE 94/9/EG (SPECIAL DESIGN EX):.....	9
5.4.1	<i>General</i>	9
5.4.2	<i>Extended marking</i>	9
6	INSTALLATION MANUAL	10
6.1	GENERAL.....	10
6.2	EXTENDED INSTALLATION INSTRUCTION FOR APPLICATION ACC. TO ATEX-GUIDELINE 94/9/EG.....	10
6.2.1	<i>Details for safe operation</i>	10
6.2.2	<i>Details for safe installation</i>	10
6.2.3	<i>Details for a safe application area</i>	10
7	OPERATING MANUAL	11
7.1	COUPLING PROCESS.....	11
7.1.1	<i>Installation of the ready to couple position</i>	11
7.1.2	<i>Mechanical connection of coupling and adaptor</i>	12
7.1.3	<i>Opening of the valves</i>	13
7.2	UNCOUPLING PROCEDURE.....	14
7.2.1	<i>Closing of the valves</i>	14
7.2.2	<i>Mechanical disconnection of coupling and adaptor</i>	15
8	MAINTENANCE AND FUNCTION TEST	16
8.1	CLEANING.....	16
8.2	MAINTENANCE AND FUNCTION TEST.....	16
8.2.1	<i>Maintenance includes the following points:</i>	16
8.2.2	<i>The function test contains the following points:</i>	17
8.3	INSTRUCTION FOR DISMANTLING AND ASSEMBLY OF THE SEALING MODULE.....	18
9	TEST	20
10	LUBRICATION !	21
11	STORAGE	22
12	SHUT-DOWN	23
13	ORDER NUMBER CODE	24
14	INDEX	25

2 General

This manual contains all regulations for operation, commissioning and maintenance of the coupling.

All information and notes in this operating manual were collated while taking into consideration the valid regulations, the current engineering related status of development as well as our many years of experience and acquired knowledge.

Translations of this operating manual were also produced according to the best of knowledge. However, we cannot assume liability for any translation errors. The German version provided for this operating manual is considered the authoritative version.

The actual scope of delivery can deviate from the explanations and graphic representations described herein under certain circumstances, e.g. in the case of special designs, utilization of additional order options or because of state-of-the-art technical alterations.

If you have any questions, please contact the manufacturer.



This operating manual must be read carefully before starting work on or with the equipment, in particular before commissioning!

The manufacturer assumes no liability for damage or faults arising from non-compliance with the instructions in this operating manual.

The operating manual must be kept directly with the equipment and be accessible to all persons who work on or with the equipment.

It is not permitted for the operating manual to be passed to third parties and if applicable this will incur damage compensation.

All other rights reserved.

Before commissioning the device must be checked for being not defective and its technically perfect function.

The German version is the original.

We reserve the right to make technical alterations to the product within the context of improving the usage properties and further development.

The operating manual remains our property.

Any reproduction, use by or communication to third parties incurs a penalty and will be pursued by court action (copyright law against unfair competition, BGB [German Civil Code]).

All rights reserved in the case of a patent award (Paragraph 7, Section. 1 of the patent law - PG) or entry as a patented design (Paragraph 5, Section 4 of the patented design law - GMG).

Safety instructions

3 Safety instructions

Using these couplings does not release the customer from his obligation to comply with the pertinent work safety regulations e.g. operational safety ordinances, etc. The duty to take due care by the operator of the couplings includes planning measures to ensure proper operation and monitoring their implementation.

Hazard notes

If the wrong product has been selected or if there is improper use or maintenance has been omitted, then hazards arise and personal injuries and material damage can occur from:

- Hazardous emission of fluid or individual particles/coupling parts
- Function impairments of connected systems or tools
- The metal parts of coupling and adaptor are not thermally protected. You can be burned if you touch these parts at high media temperatures. According to the ambient temperature valve lever and ring grip can also become unbearably hot. For that reason suitable, sufficiently long protective gloves should be worn.

The operator must in particular make sure that

- The couplings are only used according to the intended purpose.
- The couplings are only operated in a perfect, functioning condition.
- The operating manual is always in a legible condition and is available in its entirety to operating personnel.
- The operating personnel are sufficiently acquainted with the working method and the safety notes for the coupling.
- The coupling is sent to our factory for repair work.
- During operation of the coupling, no safety devices are removed and/or deactivated.
- Before installing or dismantling the coupling, you have made sure that the coupling has not been pressurized.

After completing assembly and installation work and before commissioning the coupling, observe the following points:

Check once again that all screw connections are securely fitted.

Before commissioning the coupling, a function test must be carried out (see maintenance and function test).

4 Warranty

The warranty conforms to:

the regulations agreed in the purchase contract and
the “General Conditions for Delivery and Capacity” of C.K. Walther GmbH & Co. KG
of the state which was valid at the date of the purchase contract.

Wearing parts are generally excluded from the warranty.
Typical wearing parts of products from company C.K. Walther GmbH & Co. KG
are for example:

- seals
- springs

Product description of self sealing coupling

5 Product description of self sealing coupling

The coupling connection comprises:

self sealing coupling	1-BF-025-0-.....-..(Z..)
self sealing adaptor	1-BF-025-2-.....-..(Z..)

5.1 Intended use

- The self sealing coupling is used to connect two lines.
- Both coupling halves can be connected and disconnected under working pressure.
- The coupling is carried out with an automatic lock (one hand-operation).
- The valves are separately opened and closed with a lever operated eccentric drive.
- It is squirt free when coupling and uncoupling.
- The self sealing coupling is used for both non-lubricating and lubricating media.
- The self sealing coupling is suitable for all media/applications: However, the media resistance depends on the used materials.
The self sealing coupling is especially used in the chemical industry.
- Consult with C.K. Walther for all media resistances which are unclear.

5.2 Technical data

- The working pressures of the self sealing coupling depend on the component materials.
- When determining the working pressures with standardized threaded connections, the highest permissible working pressure of the connection must be taken into consideration.

Working pressure:

Material : stainless steel	
coupled :	max. 40 bar
uncoupled:	max. 40 bar

Cv values:

self sealing coupling	- >	self sealing adaptor	= 14.7
self sealing adaptor	- >	self sealing coupling	= 14.7

Leakage volume during uncoupling:

1 ml

Working temperature:

-10°C to +200°C

Product description of self sealing coupling

- The safe function of the coupling requires media cleanness. Media contaminations can lead to leakages. We recommend a filter mesh of 25 µm.
- Media can change rapidly or also over a longer period. That can interfere with the safe function of the coupling. The coupling is not suitable for media which show such appearances during operation of the coupling.
- The permissible media temperatures depend on the permissible temperatures required for the used component materials. In critical cases, e.g. at very high temperatures or also very low temperatures the required temperature limits which are subject to the corresponding medium are to be agreed with the manufacturer. Freezing of the medium in the coupling parts stops their functionality. In addition frozen water can internally plastically deform and destroy the coupling parts. Also external water at the coupling can lead to its shut-down during freezing.
- The self sealing coupling is not determined for any types of use other than those listed here.
- Safe operation is not guaranteed if the self sealing coupling is used contrary to its intended use.
- The operator of the self sealing coupling is responsible for all personal injuries or material damage that occur from non-intended use; the manufacturer assumes no responsibility in these cases.

5.3 Optional Features

EX = ATEX – version

Product description of self sealing coupling

5.4 Extended product description for application acc. to ATEX-guide line 94/9/EG (special design EX):

5.4.1 General

Only non-sparkling materials may be used.

Non-sparkling materials are 1.4305 or equivalent materials.

Furthermore brass with different surfaces (f. ex. chrome-plated, nickel-plated).

Further on it must be assured that the seal is resistant against and suitable for the flowing through media. Also the temperature resistance of the seals must be guaranteed. This must also be considered for the marking acc. to chapter 5.5.2.

5.4.2 Extended marking

The coupling fittings are marked with



As the surface temperature of the self-sealing couplings are determined by the temperature of the fluids, the temperature category or the highest surface temperature must be specified by the operator while the safe temperature distances acc. to EN 13463-1 must be observed and the maximum temperature resistance of the coupling materials and seals are taken into consideration.

The marking of the temperature class must be effected readily visible by the operator.

The determination of the temperature class must be made acc. to the following table:

Max. temperature of fluids	Temperature class
75	T6
90	T5
130	T4
195	T3
295	T2
445	T1

The couplings are not admitted for the temperature classes T1 and T2 and may not be marked for that by the operator.

6 Installation manual

6.1 General

The self sealing coupling is to be integrated into the line network while taking into account the general accident prevention guidelines so that:

- perfect operation is guaranteed in accordance with the operating manual (e.g. clearance of lever).
- external damage to the unit and all mobile parts is excluded.

Before installing the self sealing coupling and the self sealing adaptor in a pipeline network, make sure that the pipeline network has been sufficiently rinsed/blown through and/or cleaned.

See point 8 for assembling and dismantling the self sealing coupling and self sealing adaptor into and out of the line system.



After completing the installation work, perform a function test both depressurised and under working pressure, as described in the operating instructions.

6.2 Extended installation instruction for application acc. to ATEX-guideline 94/9/EG

6.2.1 Details for safe operation

For the use of self sealing couplings as a hose connection it must be guaranteed that in case of pressure strikes the tumbling of the self sealing coupling can be avoided by fixing at suitable constructions. In principle it must be observed that the self sealing coupling cannot strike on hard objects which could produce strike sparks when touching the housing.

6.2.2 Details for safe installation

The self sealing couplings may only be connected to pipe- and hose systems which are suitable for electrostatic discharge and which are connected to the ground potential.

6.2.3 Details for a safe application area

The self sealing couplings may be used according to the class of devices 2 in areas susceptible to explosions where potentially explosive mixtures of gas, steam, mist and air are available.

Maintenance instructions Function test

7 Operating manual

The self sealing coupling elements may only be used for the specified purposes in order to avoid critical injury to personnel and damage to the locking elements during use.

Function description of the coupling

7.1 Coupling process

7.1.1 Installation of the ready to couple position

The front adaptor component must be in non-relocatable position. This is the condition for the mechanical connection of adaptor and coupling. This ready to couple position for use is to be made if necessary as follows:

The knurled ring is to be turned with its groove into the position „relocatability“. The now relocatable adaptor front part is to be completely moved into the direction to the coupling part. In this position the knurled ring is to be turned with its groove into the „lock position“. Subsequently the non-relocatable ready to couple position for use is to be checked by trying to reciprocate the adaptor front part.

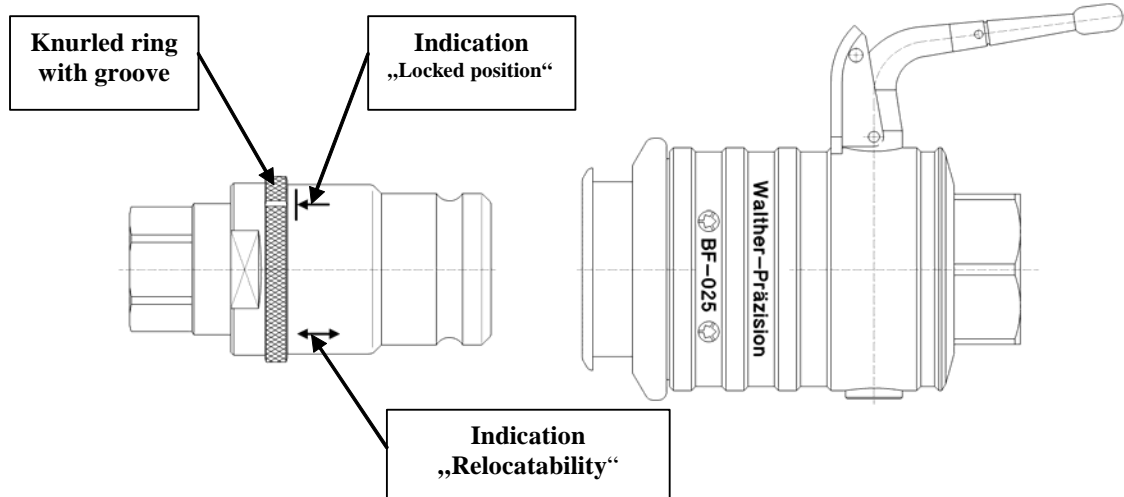

Maintenance instructions Function test

7.1.2 Mechanical connection of coupling and adaptor

The coupling and/or the adaptor is to be mechanically connected by inserting into the respective counterpart. Due to the concave surface of the coupling front side it can occur that the adaptor does not immediately find its inserting position. The operator will find this position by swivelling the adaptor and/or coupling.

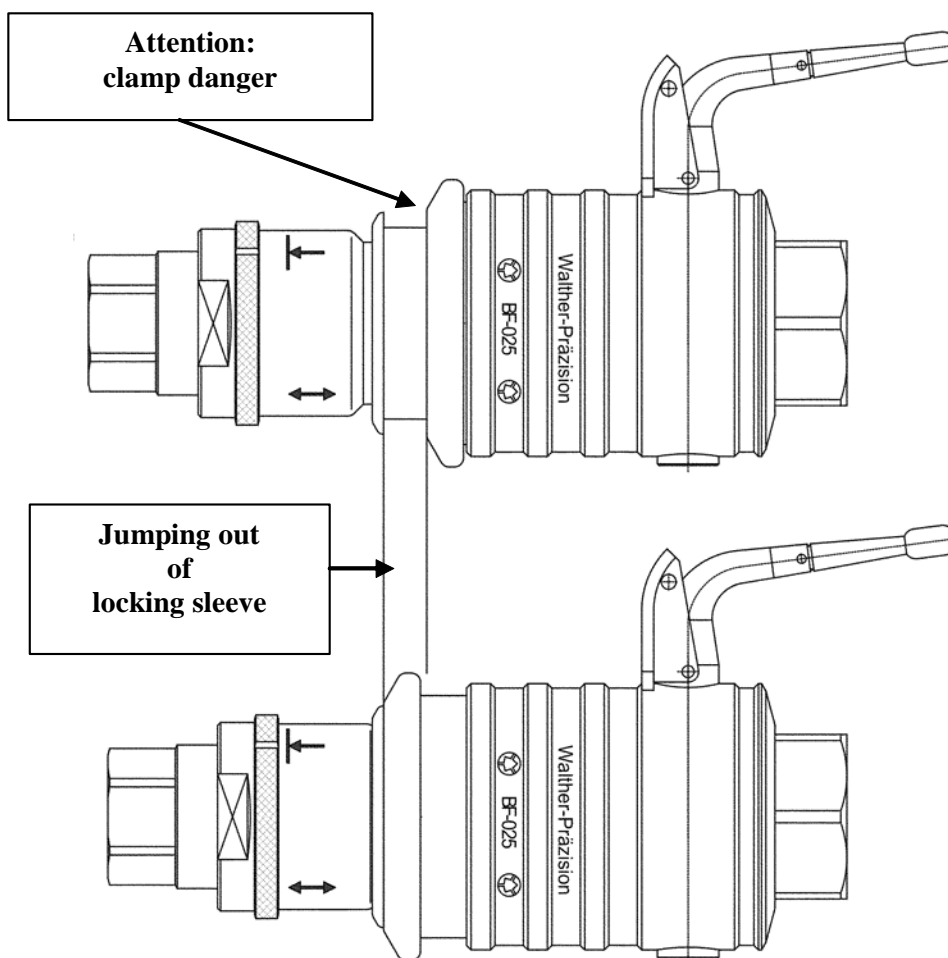

Shortly before reaching the finally locked position the locking sleeve jumps forward against a fixed collar. This is the feature that the coupling counterparts are mechanically locked. The sleeve is spring loaded so that there is the danger that you get your finger squashed during the coupling process.

Maintenance instructions Function test

7.1.3 Opening of the valves

To open the valves the locked position must be released by pressing the ratchet. If the locked position should be secured with a locking bolt it is to be removed before. The lever is to be swivelled anticlockwise by 180°.

Thus the lever shows into the direction of the adaptor when the valves are opened.

The valve opening process should be carried out continuously as it possibly results in strong flows which lead to more or less strong vibrations.

Under no circumstances the coupling may be operated if the lever stands crosswise to the flow direction (i.e. after a 90° swivelling only).

If the valves are completely opened attention is to be paid that the ratchet also locks in this position.

This position is to be preferably secured with locking bolts so that it does not result in unintentional closing of the valves.

The adaptor is secured against uncoupling by an internal locking circuit. An uncoupling is compulsorily only possible if valves are closed. Do not try to uncouple the coupling connection with force or with the aid of tools or the like.

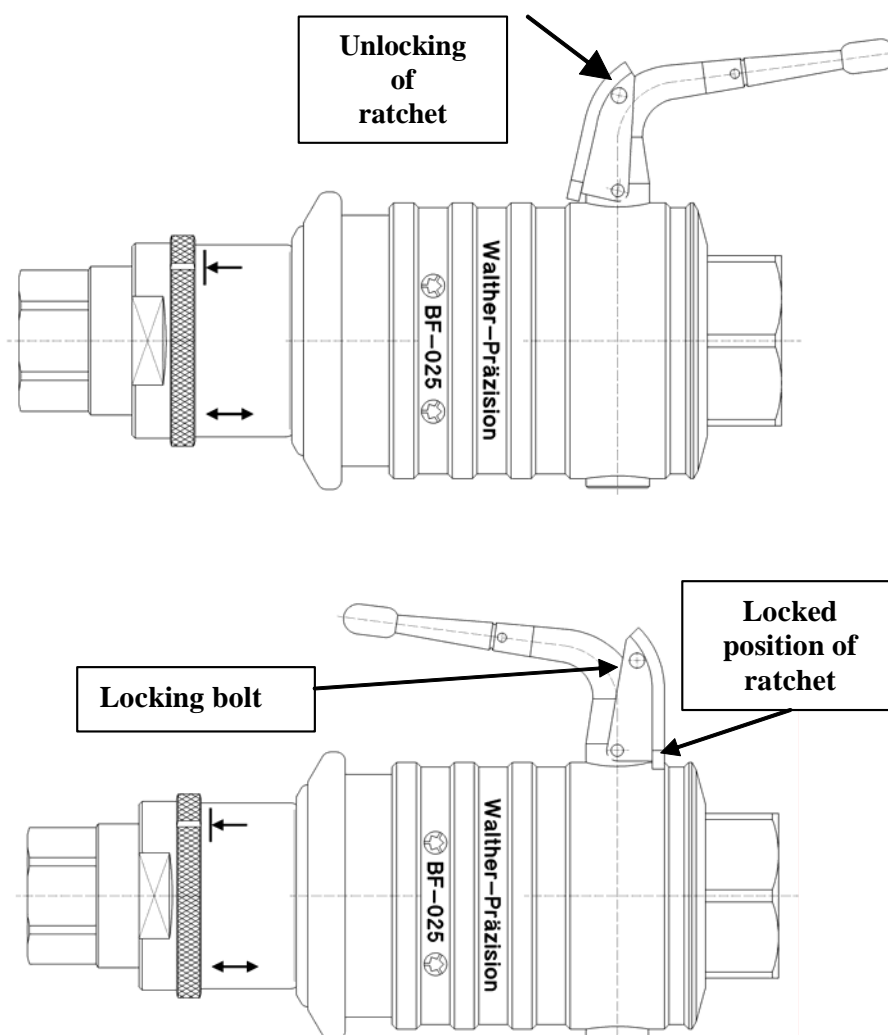

Maintenance instructions Function test

7.2 Uncoupling procedure

7.2.1 Closing of the valvese

Before the adaptor and the coupling can be uncoupled the valves must be compulsorily closed.

For this purpose the locked position must be released by pressing again the ratchet.

If the locked position was secured by a locking bolt the locking bolt is to be removed. The lever is continuously swivelled back by 180°.

The ratchet must snap in and if necessary it is to be secured with the locking bolt

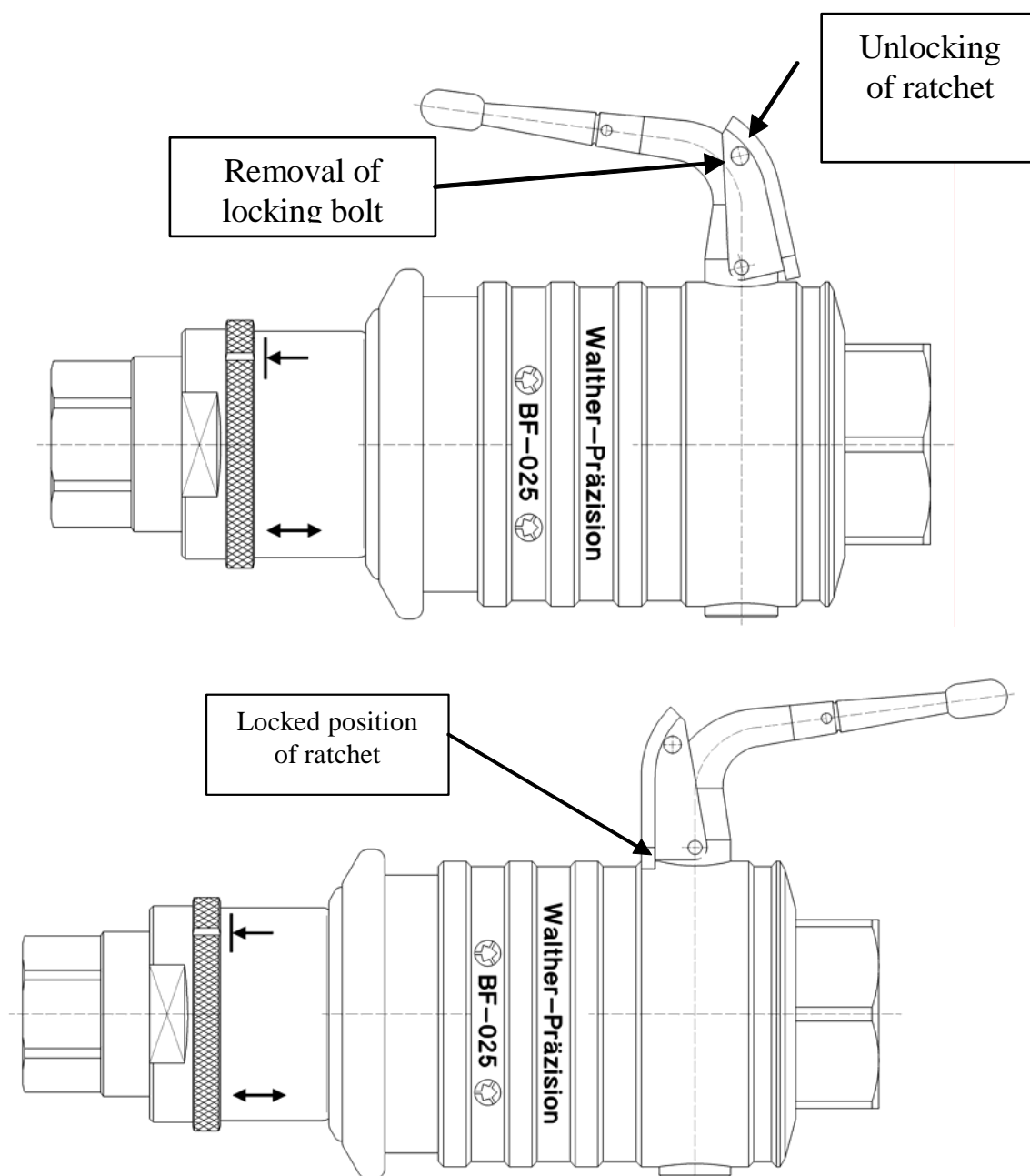

Maintenance instructions Function test

7.2.2 Mechanical disconnection of coupling and adaptor

Only if the valves are closed coupling and adaptor can be disconnected.

The mechanical lock is opened by pressing the front bulge of the locking sleeve and the adaptor can be taken from the coupling.

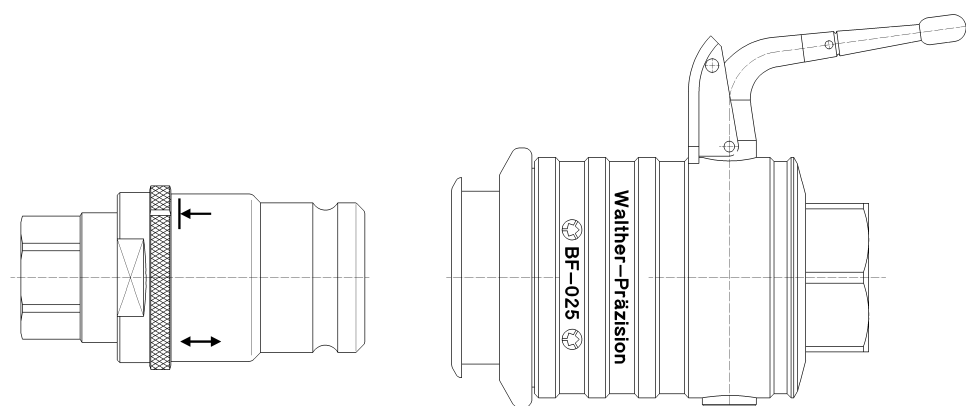
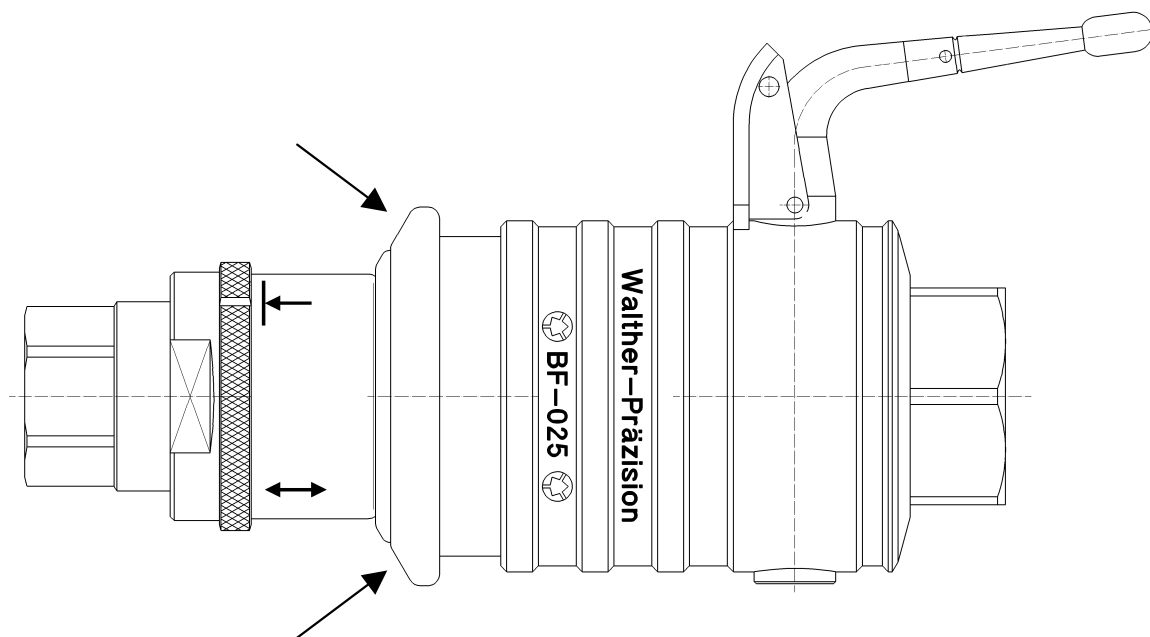

Maintenance instructions Function test

8 Maintenance and Function test

Preventive maintenance measures

WALTHER self sealing couplings are to be handled in such a way that external damage to the elements and to all mobile parts are excluded.

8.1 Cleaning

The outside contours are smooth as far as possible and thus they can be easily cleaned. The front of the coupling is to be wiped with a clean, soft cloth without dirt ingress into the groove.

The adaptor is to be cleaned first of all at its outside contour. Then the knurled ring with its groove is to be turned into the position „relocability“ and the adaptor front part can be pushed back.

Thus the convex curved front surface is free and can be well cleaned.

The detergents must be suitable for the built-in o-rings from elastomer materials.

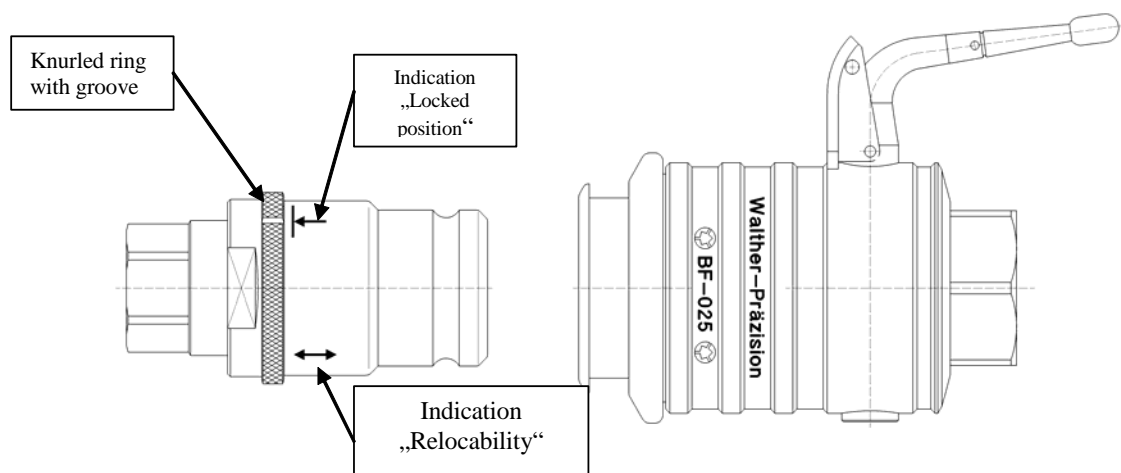

8.2 Maintenance and Function test

Maintenance work and function test must be carried out at a suitable interval irrespective of the operating conditions to guarantee the function of the self sealing coupling and thereby also to protect the operator.

We recommend lightly greasing the plug-in areas to minimize operating forces and to extend the service life of the self sealing coupling.

8.2.1 Maintenance includes the following points:

- An external visual inspection for damage and contamination is to be carried out for the self sealing coupling and the self sealing adaptor.
- Contamination in externally accessible function areas (sealing area, operating elements) is to be removed simply by wiping.

Maintenance instructions Function test

If there are damaged, torn or corroded parts the self sealing coupling and the self sealing adaptor must be dismantled and sent to the manufacturer for repair works.

In the case of torn, brittle and old seals and with severe contamination the self sealing adaptor must be dismantled and sent to the manufacturer for repair works.

The self sealing coupling has an easy to maintain sealing module on which all seals are placed. In the case of torn, brittle or old seals the customer must decide whether to send the self sealing coupling to the manufacturer for repair works or whether he exchanges the sealing module himself.

The instruction for dismantling and assembly of the sealing module is carried out under point 8.3.

The sealing module can be bought as completely mounted unit from the supplier of the self sealing coupling.

8.2.2 The function test contains the following points:

As described in the operating manual, the self sealing coupling is coupled several times, pressurized and uncoupled.

When doing this, pay attention to the following:

- Perfect, smooth-running functioning when coupling and uncoupling.
- Leak tightness of self sealing coupling in coupled and uncoupled status.

If there are damaged, torn or corroded parts the self sealing coupling and self sealing adaptor must be dismantled and sent to them manufacturer for repair works.

In case of torn, brittle or old seals and with severe contamination the self sealing adaptor must be dismantled and sent to the manufacturer for repair works .

The self sealing coupling has an easy to maintain sealing module on which all seals are placed. In the case of torn, brittle or old seals the customer must decide whether to send the self sealing coupling to the manufacturer for repair works or whether he exchanges the sealing module himself.

The instruction for dismantling and assembly of the sealing module is carried out under point 8.3.

The sealing module can be bought as completely mounted unit from the supplier of the self sealing coupling.

Please note !

If the coupling is repaired by the customer themselves, a pressure and/or leak test must be performed in any case.

The sequence and extent of this test is described in section “Test“.

Please note !

The manufacturer’s warranty shall not apply to the end product if it is repaired by other than the manufacturer, Walther-Präzision.

Maintenance instructions Function test

8.3 Instruction for dismantling and assembly of the sealing module

1. Insert assembly tool BM-01-132-001 into the coupling
2. After inserting locking sleeve jumps to the front

ATTENTION:

Locking sleeve is under initial load.
Clamp danger for fingers

3. Assembly tool is locked

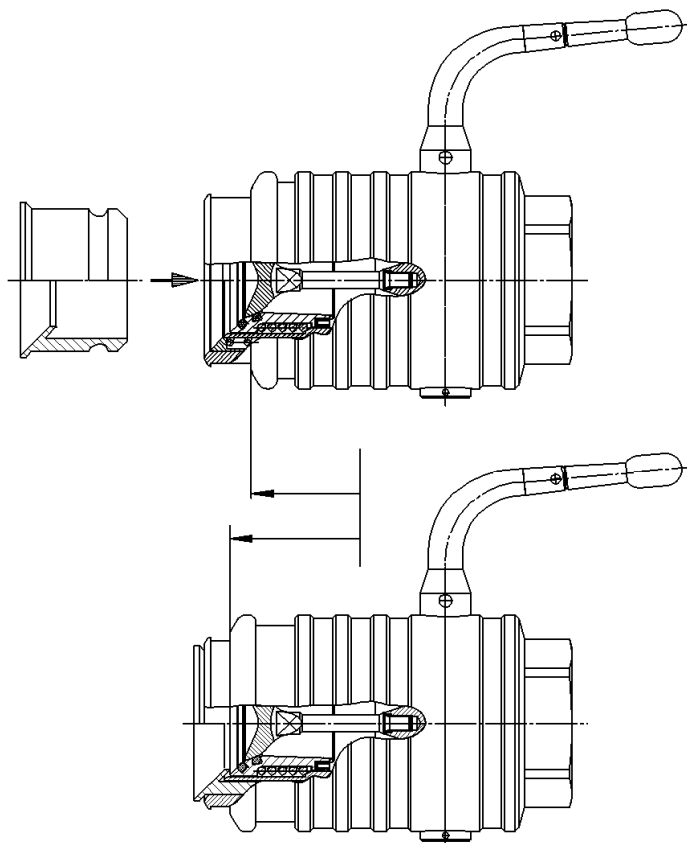

Lever
Position OPEN

4. The lever of the coupling is to be swivelled by 180° into position OPEN
5. Valve tappet must be loosened with a (cranked) flat spanner SW 12 and screwed out

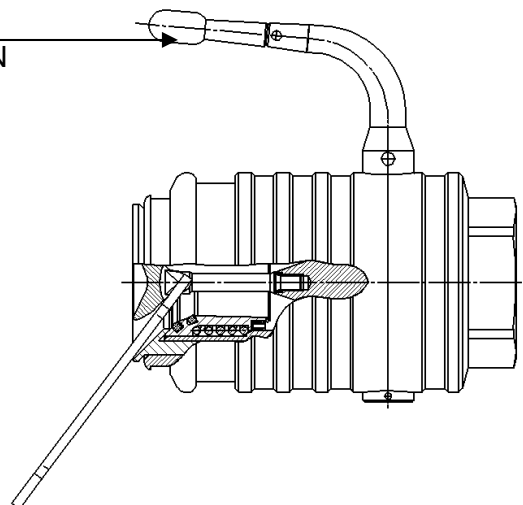

Maintenance instructions Function test

6. Take out valve tappet

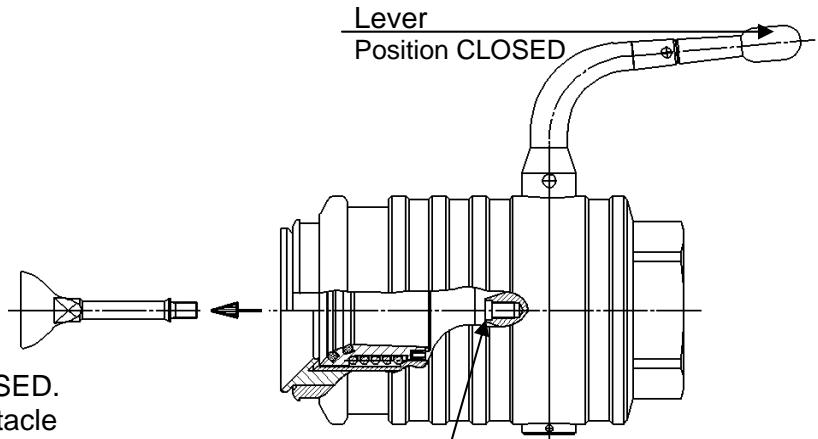

7. Swivel lever in direction CLOSED.
In doing so lead tappet receptacle
with the screwdriver in the female
thread with the screwdriver to the back!
(Avoidance of locks and surface damages)

8. Loosen assembly tool
by pushing back locking sleeve

ATTENTION:

Counterpush assembly
sleeve as it is under
spring initial tension!

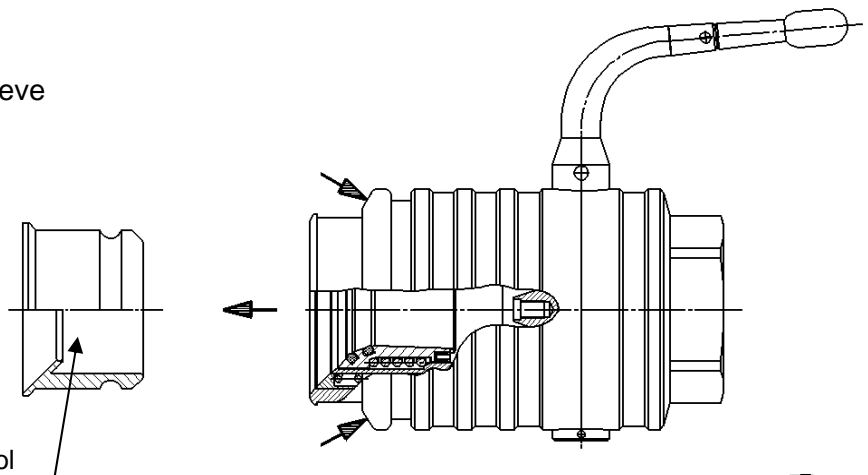

9. Take out assembly tool

10. Remove sealing module
from coupling

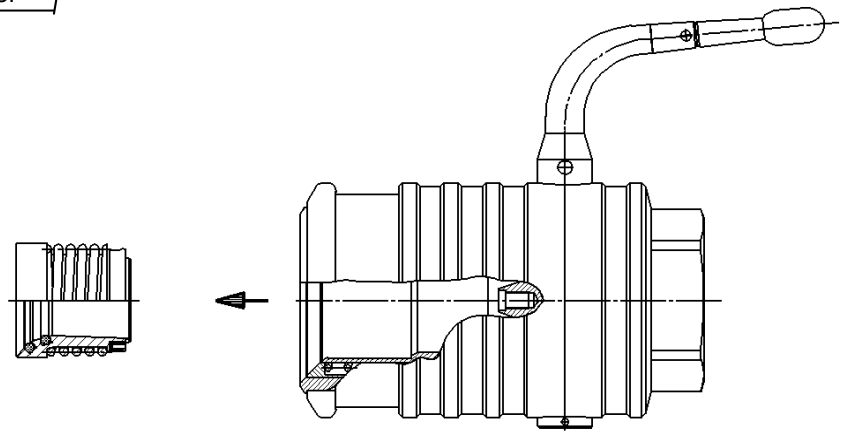

Reassembly in reverse order. (Pay attention to the guidance of the screwdriver of the tappet receptacle at point 7.)

Tightening torque: 20Nm

9 Test

(Extract from the test instructions QM-PA 2.0 of the Walther-Präzision QM system)

Description:

The coupling is tested by means of an immersion test according to the following values.

Series low pressure	
BF-025	2 bar absolut

- Test setup and test procedure

Test 1: self sealing coupling and self sealing adaptor connected

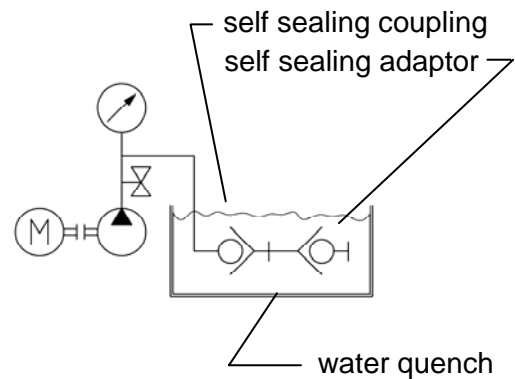

Test 2: self sealing adaptor disconnected

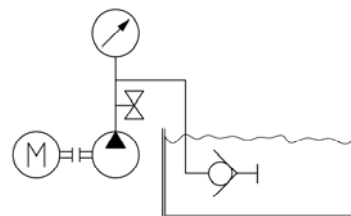

Test 3: self sealing adaptor disconnected

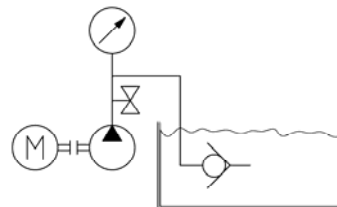

- Notes and remarks:

The dwell time per test is 10 seconds.

There must not be any bubbles during the 10 seconds dwell time.

After testing the coupling must be dried with hot air as soon as possible

(recommended: 45 – 55 °C, approx. 30 min with air stream, up to 2 hours with stagnant air, depending on the device).

- Documentation:

Please document the test pressure, test medium and name/date of each test.

10 Lubrication !

In order to minimize operating forces and to extend service life of the coupling we recommend to slightly grease plug surfaces.

Lubrication is to be carried out with greases which **do not** tend to become resin.



Caution !

The selection of the grease is to be suited to the sealing quality and the medium (e.g.: oxygen) in view of the compatibility.

11 Storage

The couplings must be stored in such a way that no damages can occur at the couplings.

The storage conditions of the couplings must comply with the guidelines for the seals as these can change in properties due to improper storage.

The following items must be kept:

- The couplings must be stored dry.
- To safely conserve the seals and that means also the couplings they should not be stored under the effect of daylight.
- For protection against oxygen the seals and also the couplings shall be stored into the packing.

12 Shut-down

At the end of the service life the coupling or its components have to be disposed non-polluting and according to the legal regulations.

For that the local public or private disposal societies should be taken.

13 Order number code

1.	2.	3.	4.	5.	6.	7.	8.	9.
□	□□	□□□	□	□□□□□	□□	□	□□□	□□
□	□□	□□□	□	□□□□□	□□□□	□	□□□	□□

1. Subject group
2. Series
Series description consists of either two letters or two digits.
3. Nominal size / nominal width
It is rounded up or rounded down to full units.
The indication can be numerical or alphanumeric.
4. Type of product and design
5. Type of connection
6. Material:
xx-x and xxxx possible
7. Material (seal version):
xx-x and xxxx possible
8. Y- or Z-design
9. Optional features

14 Index

A

According to intended purpose.....	5
Acquired knowledge.....	4
adaptor.....	11, 12, 13
Adaptor.....	12, 14, 15, 16
Adaptorl.....	5
Alterations.....	4
Assembling.....	10
Assembly.....	5
Automatic lock.....	7

C

class of devices.....	10
Clean Break Safety Coupling.....	1
Cleaned.....	10
Clearance.....	10
Commissioning.....	4, 5
concave surface.....	12
connection.....	24
corroded.....	17
Corroded.....	17
coupling.....	11, 23
Coupling.....	5, 11, 12, 14, 15, 16
Coupling connection.....	7
Coupling halves.....	7
Coupling process.....	11
Couplings.....	5
Customer care.....	2
Cv values.....	7

D

Damage.....	4, 5
Damage compensation.....	4
damaged.....	17
Damaged.....	17
daylight.....	22
Detergents.....	16
Dismantling.....	10
Disposal societies.....	23
dry.....	22

E

Eccentric drive.....	7
Equipment.....	4
Experience.....	4
explosive mixtures.....	10
Extended marking.....	9

F

Faults.....	4
Fluid.....	5
Function.....	5
Function test.....	5, 16, 17
Functionality.....	2

G

General.....	4
General accident prevention guidelines.....	10

H

Hazard notes.....	5
Hazardous emission.....	5

I

Implementation.....	5
Improvement.....	4
Index.....	25
Inhaltsverzeichnis.....	3
Inspection.....	2
Installation manual.....	10
Intended use.....	7

K

Knurled ring.....	11, 16
-------------------	--------

L

Leakage volume.....	7
Legible condition.....	5
Lever.....	10
Liability.....	4
Lock position.....	11
locking bolt.....	14
Locking bolt.....	13
Locking bolts.....	13
Locking circuit.....	13
Lubrication.....	21

M

Maintenance.....	2, 4, 5, 16
Maintenance and function test.....	16
Maintenance and Function test.....	16
Maintenance work.....	16
Manual.....	4
Media temperatures.....	5
Mobile parts.....	10

<i>O</i>	
One-hand operation	7
Operating manual	10
Operating forces	16
Operating manual	1, 11
Operation	2
Operational safety ordinances	5
operator.....	5
Operators	2
original	4
<i>P</i>	
packing	22
particular.....	5
Perfect, functioning condition	5
Performance capability.....	2
Pipeline network.....	10
Pressurized	5
produce strike sparks	10
Product description.....	7
Property	4
Protective gloves	5
<i>Q</i>	
quality.....	21
questions.....	4
<i>R</i>	
ratchet.....	14
Ratchet.....	13
ready to couple position	11
Regulations	4
Reliability	2
Relocability	16
Relocatability	11
remarks	20
Repair work	5
repair works.....	17
Repair works	17
<i>S</i>	
Safety.....	2
Safety devices.....	5
Safety instructions	5
Scope of delivery.....	4
Screw connections.....	5
seals	17
Seals	17
self sealing adaptor.....	17
Self sealing adaptor.....	7, 10, 16, 17
self sealing coupling.....	7, 17
Self sealing coupling.....	7, 8, 10, 16, 17
service	21
Service.....	2
Shut-down	23
Smooth-running functioning	17
Special designs	4
Specialists.....	2
Squirt free.....	7
Status of development	4
Storage	22
Systems	2, 5
<i>T</i>	
Technical data	7
Technical equipment	2
temperature category.....	9
Temperature class	9
temperature resistance.....	9
Test.....	20
Thermally	5
Tools	2, 5
torn	17
Torn.....	17
Translation errors	4
Types of use	8
<i>U</i>	
Uncoupling procedure.....	14
Use	2
<i>V</i>	
Version	4
vibrations.....	13
<i>W</i>	
Work safety regulations	5
Working method	5
Working pressure	7
Working pressures.....	7
Working pressurese.....	7
Working temperature	7
Wrong product selection	5